

**EN**

# One Person Gym

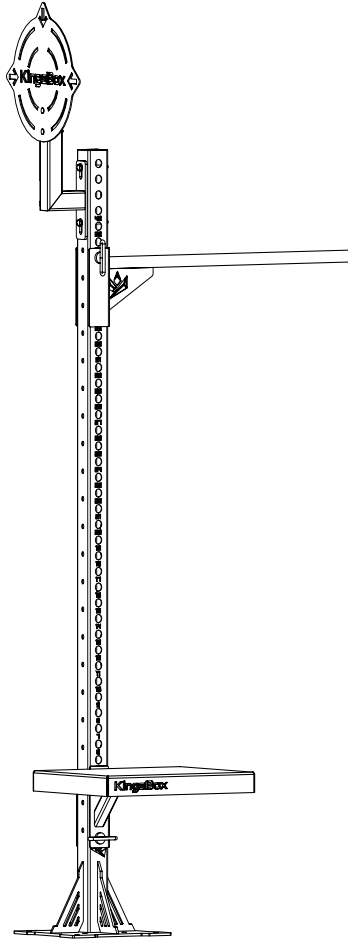

**KingsBox<sup>®</sup>**

**BUILDING BETTER HUMANS**

# Table of content

---

<b>Manufacturer information.....</b>	<b>3</b>
<b>Equipment Identification.....</b>	<b>3</b>
<b>Field of application.....</b>	<b>4</b>
<b>Equipment positioning.....</b>	<b>5</b>
<b>Correct use of the equipment.....</b>	<b>6</b>
<b>Exercise instructions.....</b>	<b>7</b>
<b>Technical information.....</b>	<b>8</b>
<b>Care and maintenance.....</b>	<b>10</b>
<b>List of tools required.....</b>	<b>11</b>
<b>Assembly elements.....</b>	<b>12</b>
<b>Assembly instructions.....</b>	<b>14</b>

# Manufacturer information

---

**TNG oprema d.o.o.**  
**Bazoviška cesta 7a, 6210 Sežana**  
**Slovenia**

**Customer service**

**Telephone: +386 18 28 08 97**

**Email: info@kingsbox.it**

**Address: Bazoviška cesta 7a, 6210 Sežana**  
**Slovenia**

# Equipment identification

---



# **Field of application**

---

## **Product classification: EN ISO 20957-1:2013 Class S**

**The free area shall not be less than 0,6 m greater than the training area in the directions from which the equipment is accessed. The free area must also include the area for emergency dimount. Where equipment is positioned adjacent to each other the value of the free area may be shared.**

**The possibility of users not being able to exist the equipment when using it according to this manual shall be avoided.**

# Equipment positioning

Total surface area (foot print):

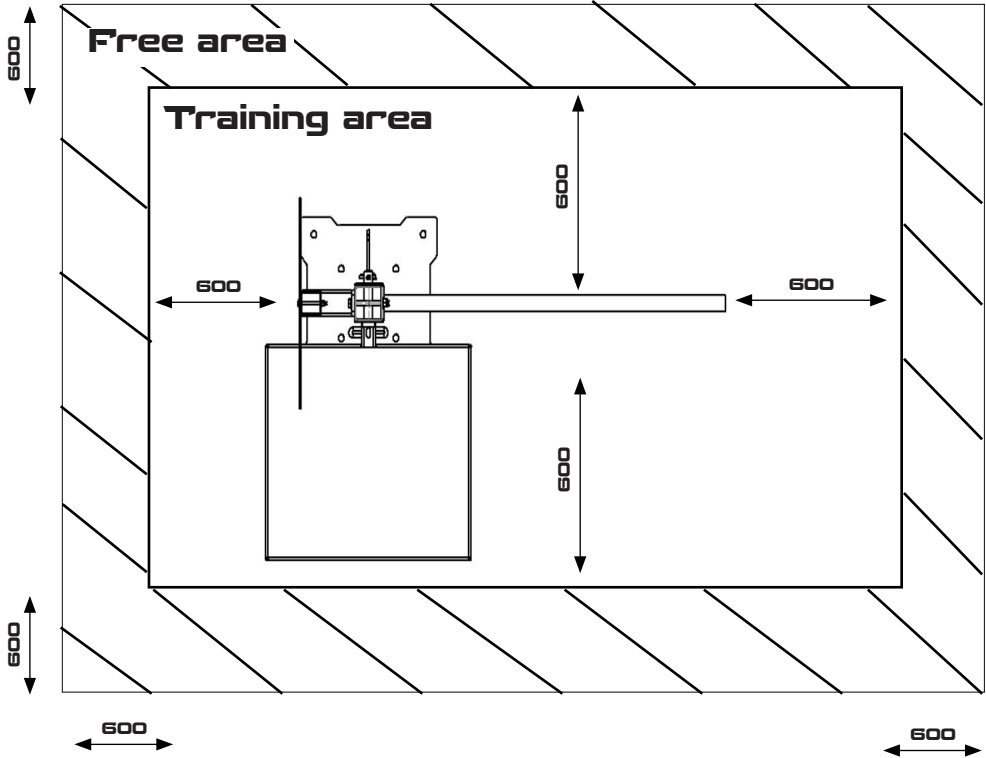

# Correct use of the equipment

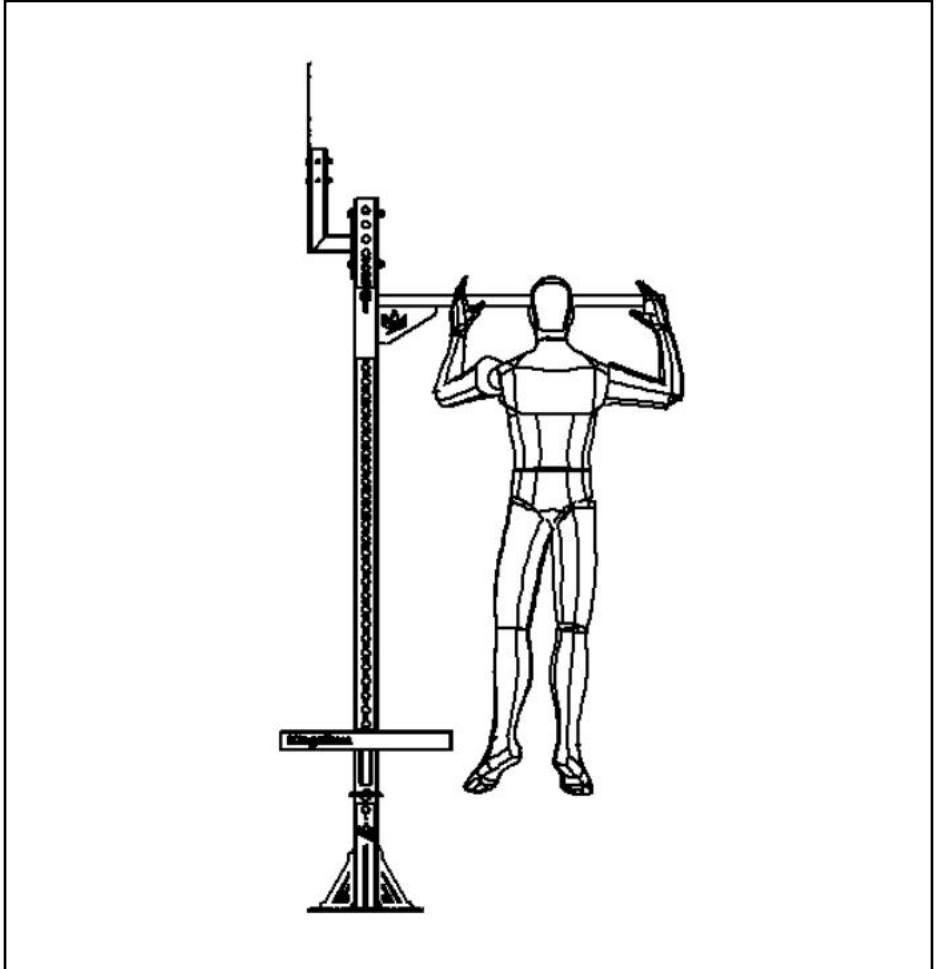

**UNSUPERVISED CHILDREN SHOULD BE KEPT  
AWAY FROM THE EQUIPMENT!**

# Exercise instructions

---

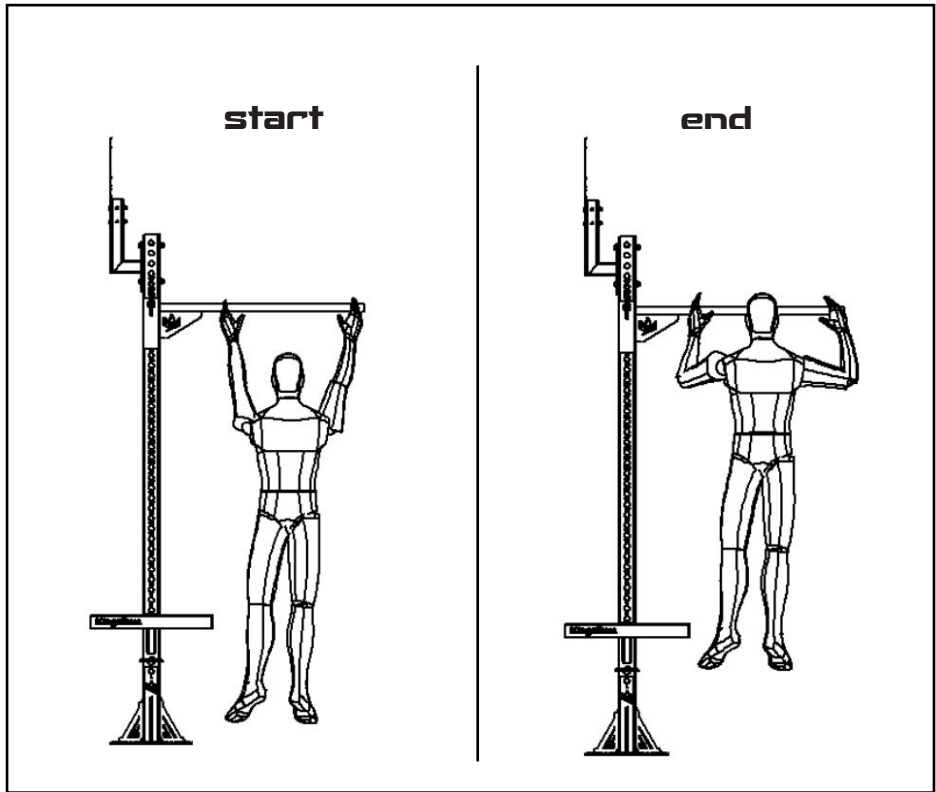

**INJURIES TO HEALTH MAY RESULT FROM  
INCORRECT OR EXCESSIVE TRAINING!**

# Technical information

---

**Total mass: 140 KG**

**Maximum user body weight: 100 KG**

**Maximum loading mass: 250 KG**

## **WARNING!**

**IF ANY OF THE ADJUSTMENT**

**DEVICES ARE LEFT PROJECTING, THEY COULD**

**INTERFERE WITH THE USER'S MOVEMENT!**

## **WARNING!**

**FREE STANDING EQUIPMENT SHALL BE IN-**

**STALLED ON A STABLE AND LEVELLED BASE!**



## Dimensions

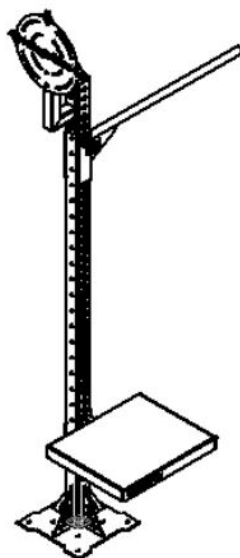
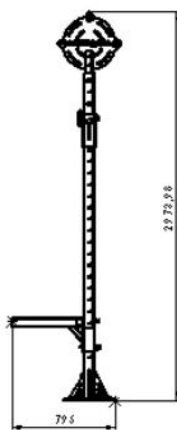
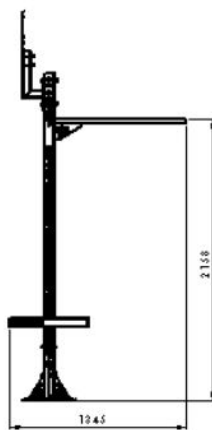

## **WARNING!**

If the structure is not secured to the ground and / or to the wall, it may overturn and / or cause damage to person or object in the immediate vicinity.

The fixing bolts for wall and/or floor are not included in the pack-age, since different types of anchor bolts must be used for differ-ent wall/floor types.

# Care and maintenance

---

## **WARNING!**

**The safety of the equipment is assured only on condition that it is carefully inspected for signs of damage and/or wear every two weeks.**

**Replace defective and worn components immediately, or alternatively remove the equipment from service.**

The equipment should always be kept clean and free of dust, in compliance with good hygiene practice, especially if it is used in a gym or by more than one person.

To clean the padded parts, use a moist cloth or a sponge and mild soap.

Every week, clean the outer parts of the equipment using a damp sponge.

## **WARNING!**

**Be careful not to rub with excessive force on the drawings and instructions shown on the labels.**

# List of tools required

---

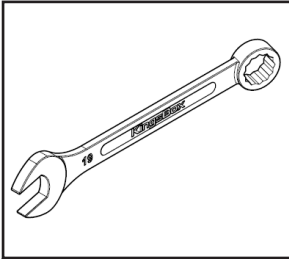

19 mm Wrench	2x
--------------	----

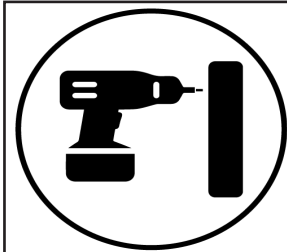

Drill	1x
-------	----

# Assembly elements

<b>SAMPLE</b>	
<div style="border: 1px solid black; width: 100px; height: 30px; margin: 0 auto; display: flex; align-items: center; justify-content: center;">             PICTURE           </div>	
<b>position</b>	<b>QTY.</b>
<b>name</b>	

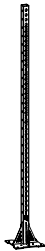
	
<b>position 1</b>	<b>1x</b>
<b>Studio Upright 2750 F</b>	

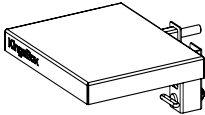
	
<b>position 2</b>	<b>1x</b>
<b>Mighty Plyo Platform</b>	

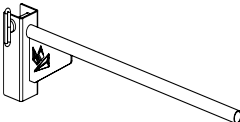
	
<b>position 3</b>	<b>1x</b>
<b>Start UP Bar F</b>	

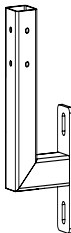
	
<b>position 4</b>	<b>1x</b>
<b>WB II. Holder S</b>	

	
<b>position 5</b>	<b>1x</b>
<b>WB Target III</b>	

# Assembly elements

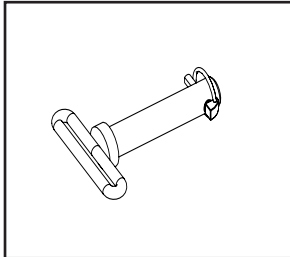

<b>position A</b>	<b>2x</b>
<b>Pin Bolt</b>	

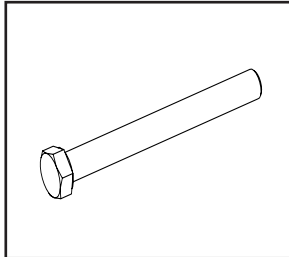

<b>position B</b>	<b>2x</b>
<b>M12x110</b>	

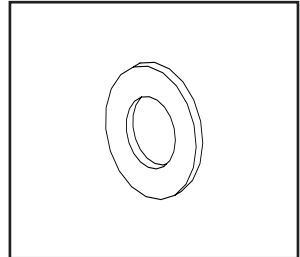

<b>position C</b>	<b>4x</b>
<b>Washer M12</b>	

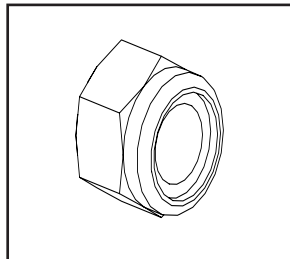

<b>position D</b>	<b>2x</b>
<b>Nut M12</b>	

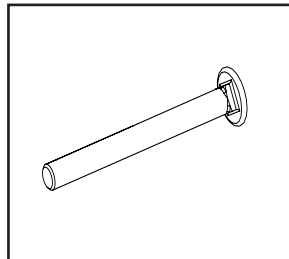

<b>position E</b>	<b>2x</b>
<b>M8x80 Torban</b>	

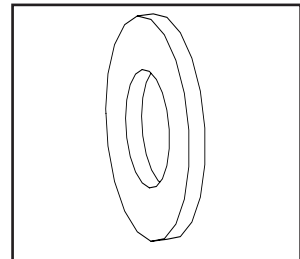

<b>position F</b>	<b>2x</b>
<b>Washer M8</b>	

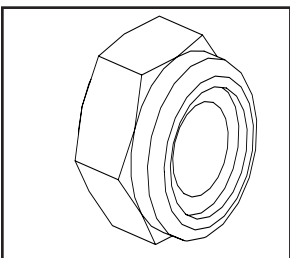

<b>position G</b>	<b>2x</b>
<b>Nut M8</b>	

# Assembly instructions

## STEP 1

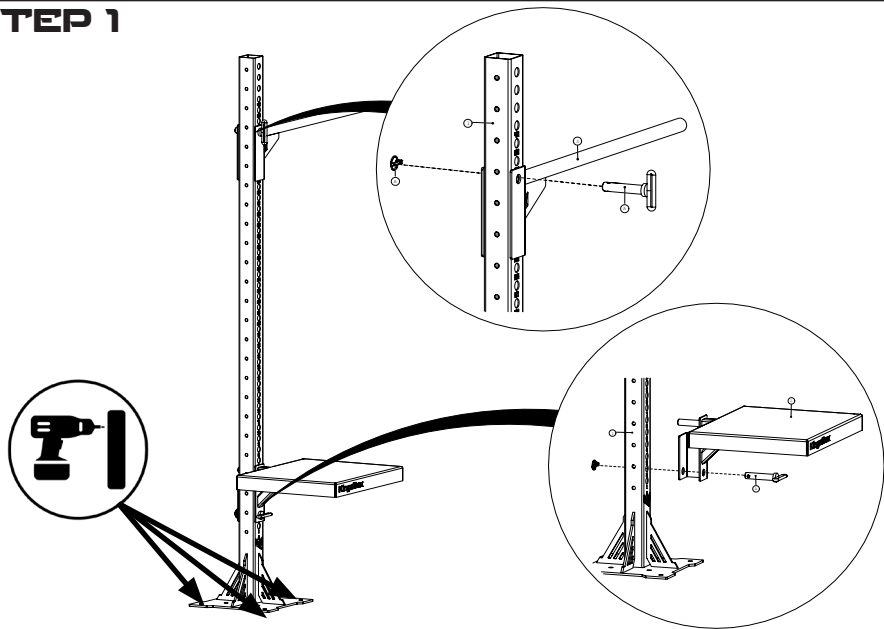

## STEP 2

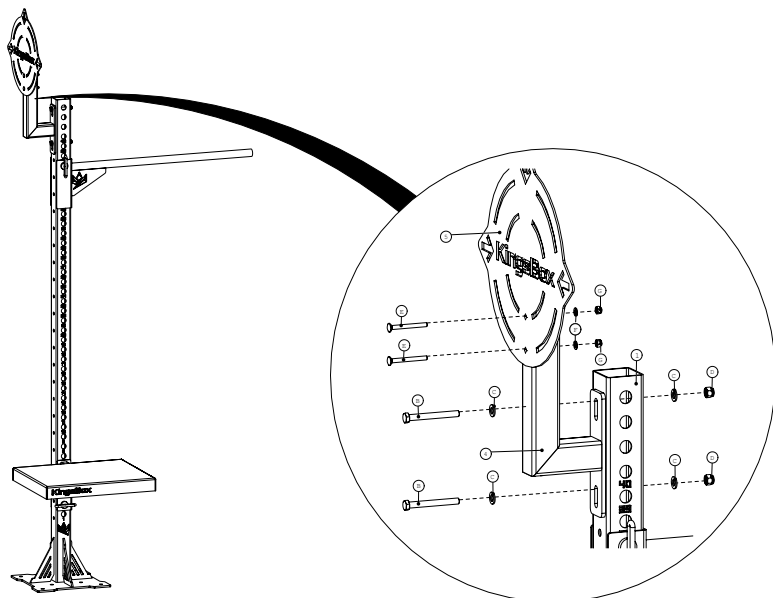

IT

# One Person Gym

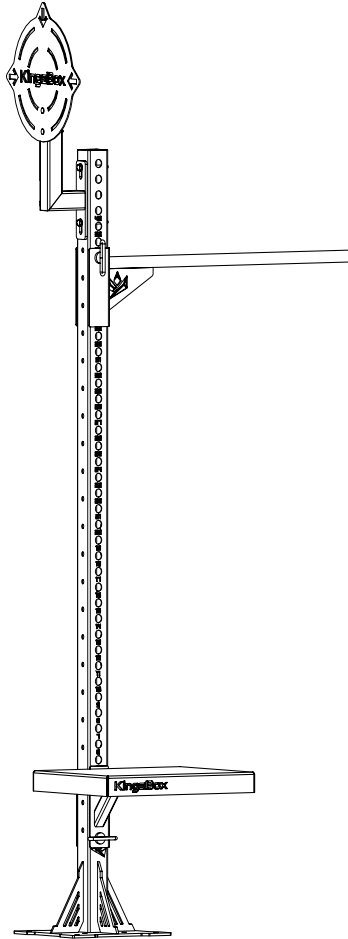

**KingsBox®**

BUILDING BETTER HUMANS

# Indice contenuti

---

<b>Dati produttore.....</b>	<b>18</b>
<b>Identificazione articolo.....</b>	<b>18</b>
<b>Utilità.....</b>	<b>19</b>
<b>Collocamento articolo.....</b>	<b>20</b>
<b>Utilizzo corretto dell'articolo.....</b>	<b>21</b>
<b>Istruzioni per l'esecuzione degli esercizi.....</b>	<b>22</b>
<b>Informazioni tecniche.....</b>	<b>23</b>
<b>Cura e manutenzione.....</b>	<b>25</b>
<b>Elenco attrezzi necessari.....</b>	<b>26</b>
<b>Elenco componenti.....</b>	<b>27</b>
<b>Istruzioni per l'assemblaggio.....</b>	<b>29</b>



## Dati produttore

---

**TNG oprema d.o.o.**  
**Bazoviška cesta 7a, 6210 Sežana**  
**Slovenia**

**Servizio clienti**

**Telefono: +386 18 28 08 97**

**E-mail: info@kingsbox.it**

**Indirizzo: Bazoviška cesta 7a, 6210 Sežana**  
**Slovenia**

## Identificazione articolo

---



## **Classificazione articolo: EN ISO 20957-1:2013 Class S**

**L'area libera attorno all'area d'allenamento dovrebbe essere di almeno 0,6m tutt'attorno all'area di utilizzo. L'area libera deve includere anche un'area per l'evacuazione o altre emergenze. Nel caso di più attrezzi posizionati uno accanto all'altro, questi possono condividere l'area libera.**

# Collocamento articolo

Planimetria articolo (foot print):

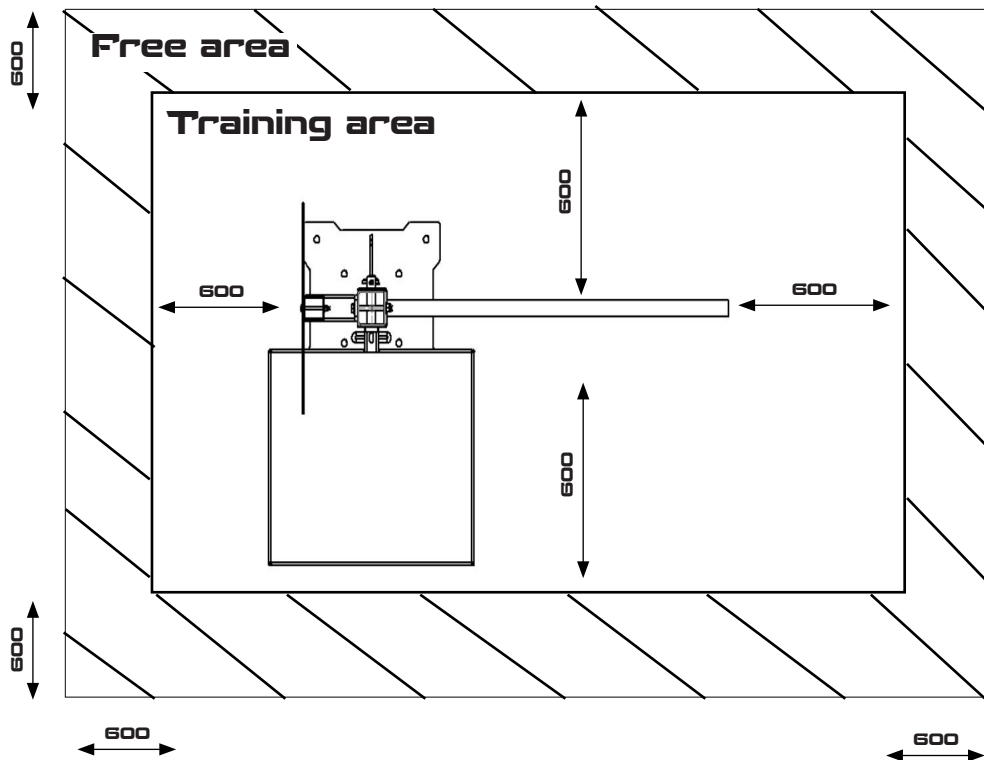

# Utilizzo corretto dell'articolo

---

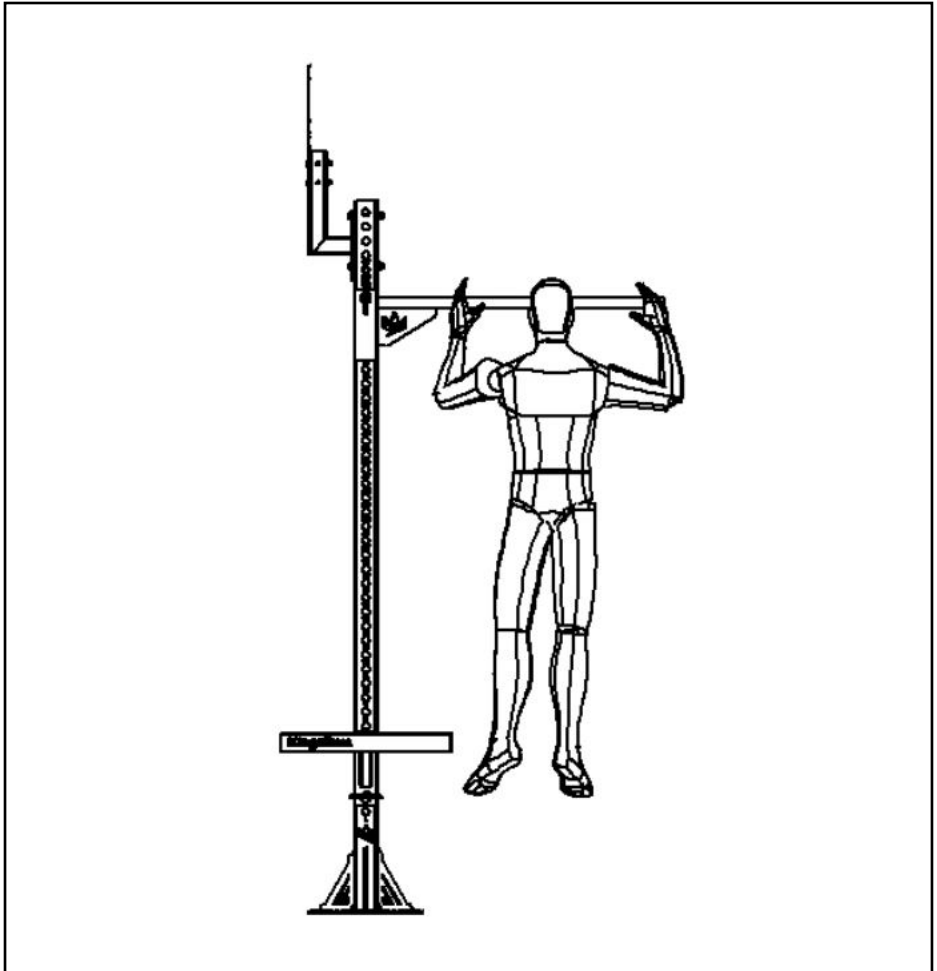

**NON PERMETTERE AI BAMBINI DI GIOCARE E/O ALLENARSI SULL'APPARECCHIO SENZA LA SUPERVISIONE DI UN ADULTO.**

# Istruzioni per l'esecuzione degli esercizi

---

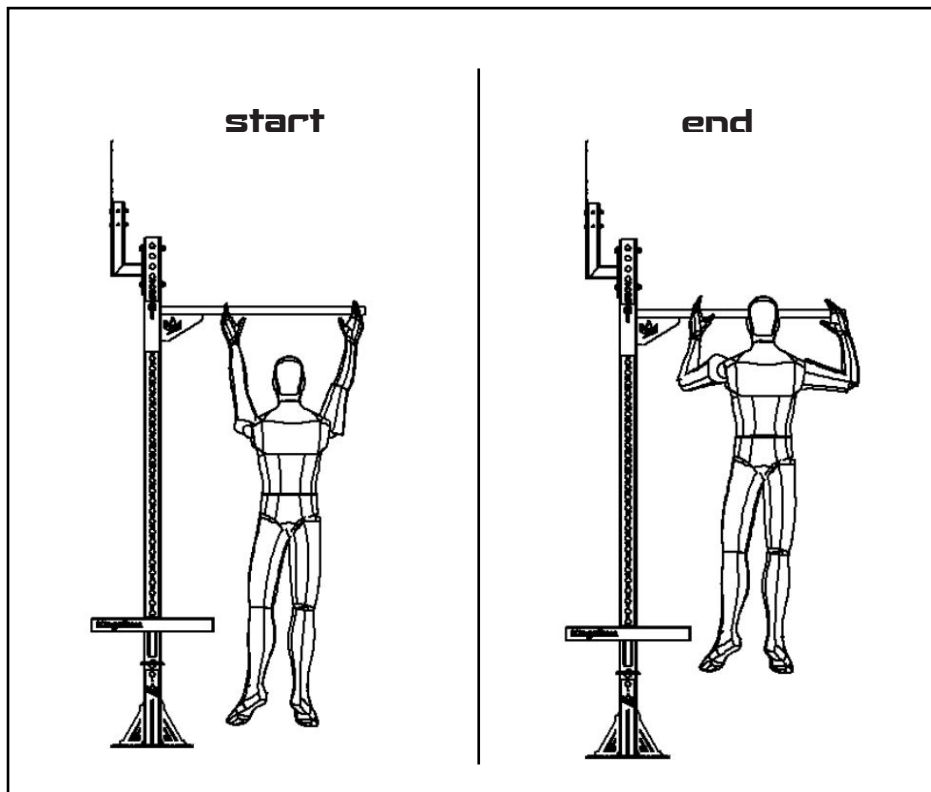

**L'ALLENAMENTO INADEGUATO O ESAGERATO  
PUÒ PORTARE AD INFORTUNI.**

# Informazioni tecniche

---

**Massa articolo: 140 KG**

**Peso massimo dell'utente: 100 KG**

**Carico massimo: 250 KG**

## **ATTENZIONE!**

**SE L'ATTREZZO CHE OFFRE LA POSSIBILITÀ DI REGOLAZIONE, RESTA IN POSIZIONE NON NEUTRALE, PUÒ OSTACOLARE I MOVIMENTI DELL'UTENTE.**

## **ATTENZIONE!**

**GLI ARTICOLI AUTOPORTANTI DEVONO ESSERE POSIZIONATI SU SUPERFICIE PIANA E STABILE.**

## **TP** DELL'ARTICOLO

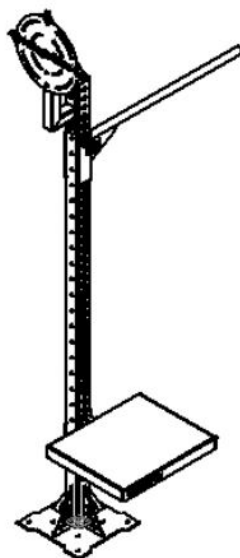
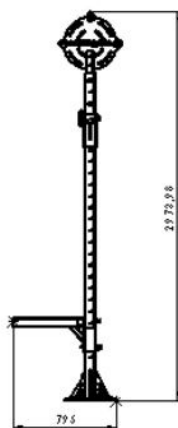
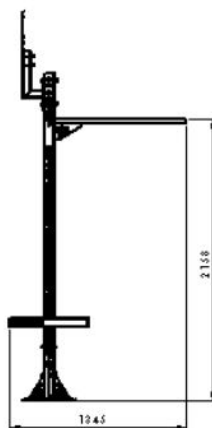

## **ATTENZIONE!**

**Nel caso in cui la struttura non sia ancorata a terra e/o muro si può ribaltare arrecando danni agli oggetti nelle vicinanze, all'utente o a persone nelle vicinanze di essa.**

**I BULLONI D'ANCORAGGIO NON SONO INCLUSI NEL PACCO IN QUANTO DIVERSI TIPI DI PAVIMENTO/MURO NECESSITANO DI DIVERSI TIPI DI BULLONI.**

# Cura e manutenzione

---

## **ATTENZIONE!**

**La sicurezza dell'attrezzatura è garantita solo se questa viene ispezionata con regolarità ogni due settimane per rilevare segni di danneggiamento e/o usura.**

**I componenti danneggiati, distrutti o usurati vanno sostituiti immediatamente oppure l'attrezzo va rimosso dall'uso.**

**I prodotti vanno tenuti puliti e spolverati, mantenendo un alto standard d'igiene soprattutto nelle palestre e negli studi dove le attrezzature vengono utilizzate da più persone.**

**Utilizzare un panno umido o una spugna ed un detergente delicato per pulire le parti imbottite.**

**Le parti esterne degli articoli vanno pulite con un panno umido ogni settimana.**

## **ATTENZIONE!**

**Fare attenzione a non strofinare con troppa forza le etichette sugli attrezzi.**



# Elenco attrezzi necessari

---

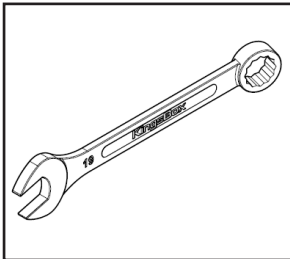

19 mm Wrench	2x
--------------	----

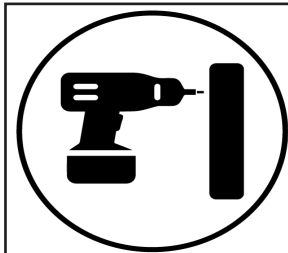

Drill	1x
-------	----

# Elenco componenti

<b>SAMPLE</b>	
<div style="border: 1px solid black; padding: 5px; width: fit-content; margin: 0 auto;">             PICTURE           </div>	
<b>position</b>	<b>QTY.</b>
<b>name</b>	

	
<b>position 1</b>	<b>1x</b>
<b>Studio Upright 2750 F</b>	

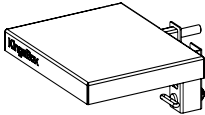
	
<b>position 2</b>	<b>1x</b>
<b>Mighty Plyo Platform</b>	

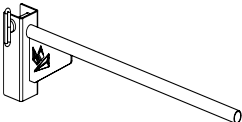
	
<b>position 3</b>	<b>1x</b>
<b>Start UP Bar F</b>	

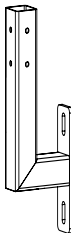
	
<b>position 4</b>	<b>1x</b>
<b>WB II. Holder S</b>	

	
<b>position 5</b>	<b>1x</b>
<b>WB Target III</b>	

# Elenco componenti

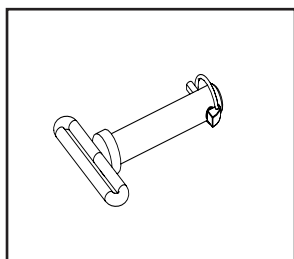

**position A** | **2x**

**Pin Bolt**

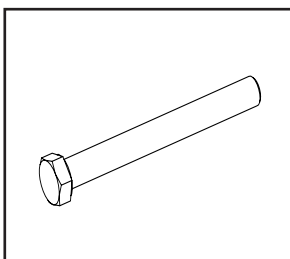

**position B** | **2x**

**M12x110**

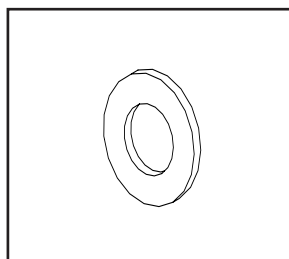

**position C** | **4x**

**Washer M12**

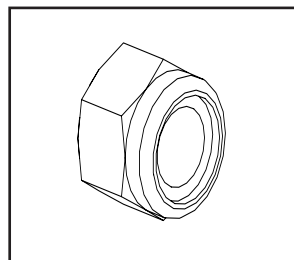

**position D** | **2x**

**Nut M12**

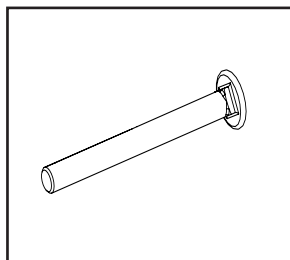

**position E** | **2x**

**M8x80 Torban**

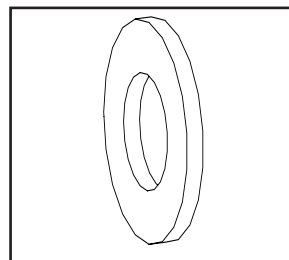

**position F** | **2x**

**Washer M8**

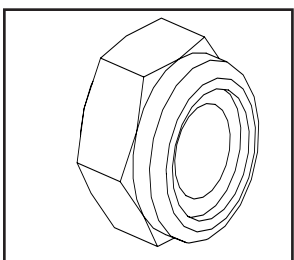

**position G** | **2x**

**Nut M8**

# Istruzioni per l'assemblaggio

## STEP 1

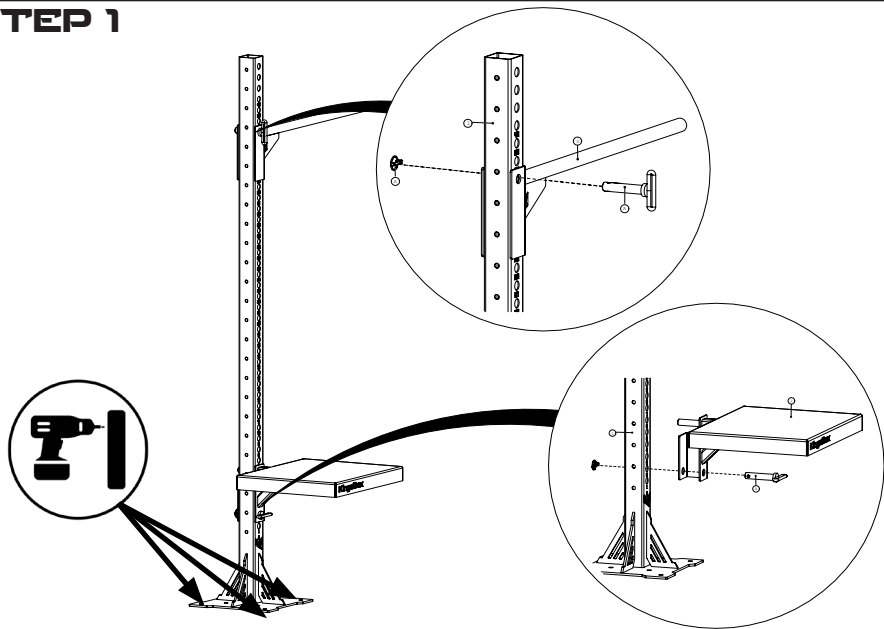

## STEP 2

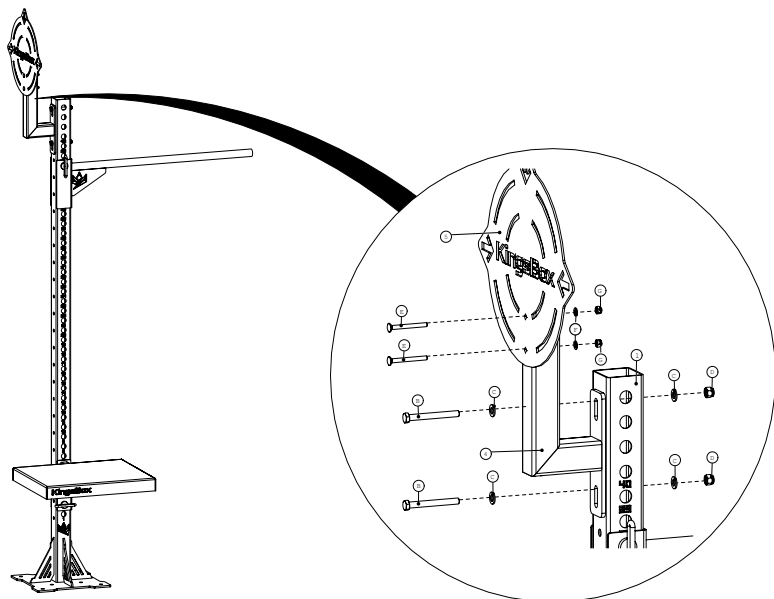

**FR**

# One Person Gym

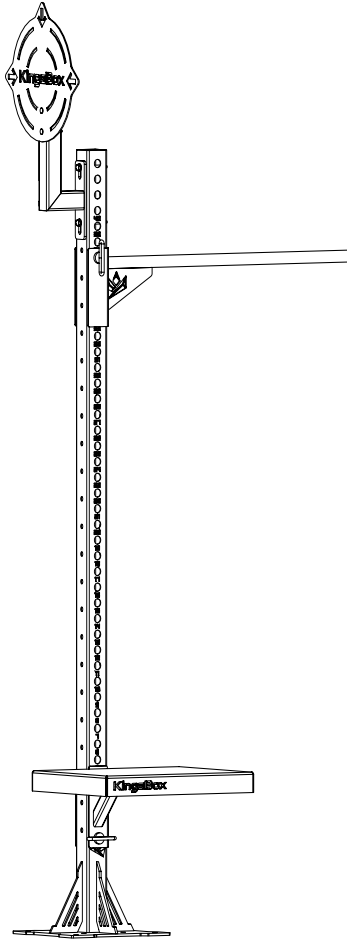

**KingsBox<sup>®</sup>**

**BUILDING BETTER HUMANS**

# **Table des matières**

---

<b>Informations du fabricant.....</b>	<b>31</b>
<b>Identification de l'équipement.....</b>	<b>31</b>
<b>Champ d'application.....</b>	<b>32</b>
<b>Positionnement de l'équipement.....</b>	<b>33</b>
<b>Utilisation appropriée de l'équipement.....</b>	<b>34</b>
<b>Instructions d'exercices.....</b>	<b>35</b>
<b>Informations techniques.....</b>	<b>36</b>
<b>Soins et entretien.....</b>	<b>38</b>
<b>Liste des outils nécessaires.....</b>	<b>39</b>
<b>Éléments d'assemblage.....</b>	<b>40</b>
<b>Instructions de montage.....</b>	<b>42</b>

# Informations du fabricant

---

**TNG oprema d.o.o.**  
**Bazoviška cesta 7a, 6210 Sežana**  
**Slovenija**

**Service client**

**Téléphone: +386 18 28 08 97**

**E-mail: info@kingsbox.it**

**Adresse: Bazoviška cesta 7a, 6210 Sežana**  
**Slovenia**

# Identification de l'équipement

---



# **Champ d'application**

---

## **Classification des produits : EN ISO 20957-1:2013 Class S**

**La zone libre ne doit pas être moins de 0,6 m plus grande que la zone d'entraînement dans les directions à partir desquelles on s'approche de l'équipement. La zone libre doit également inclure la zone pour une descente d'urgence. Lorsque l'équipement est positionné à côté l'un de l'autre, la valeur de la zone libre peut être partagée. La possibilité pour les utilisateurs de ne pas pouvoir exister avec l'équipement lorsqu'ils l'utilisent conformément à ce manuel doit être évitée.**



# Positionnement de l'équipement

Surface totale (empreinte de pied):

---

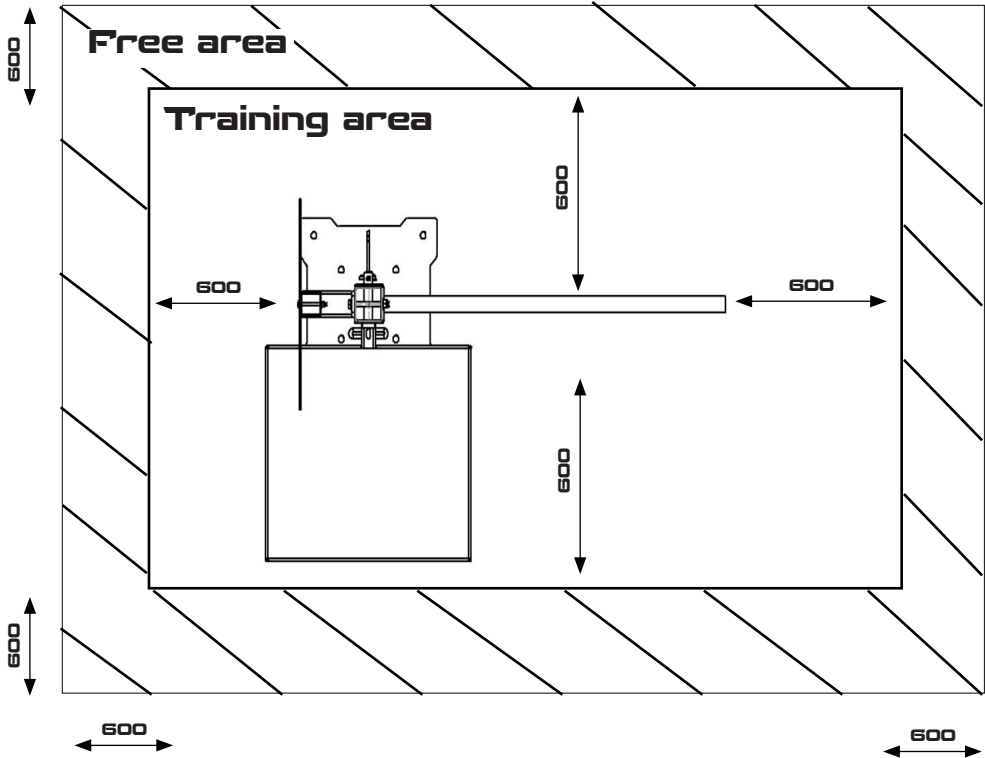

# Utilisation appropriée de l'équipement

---

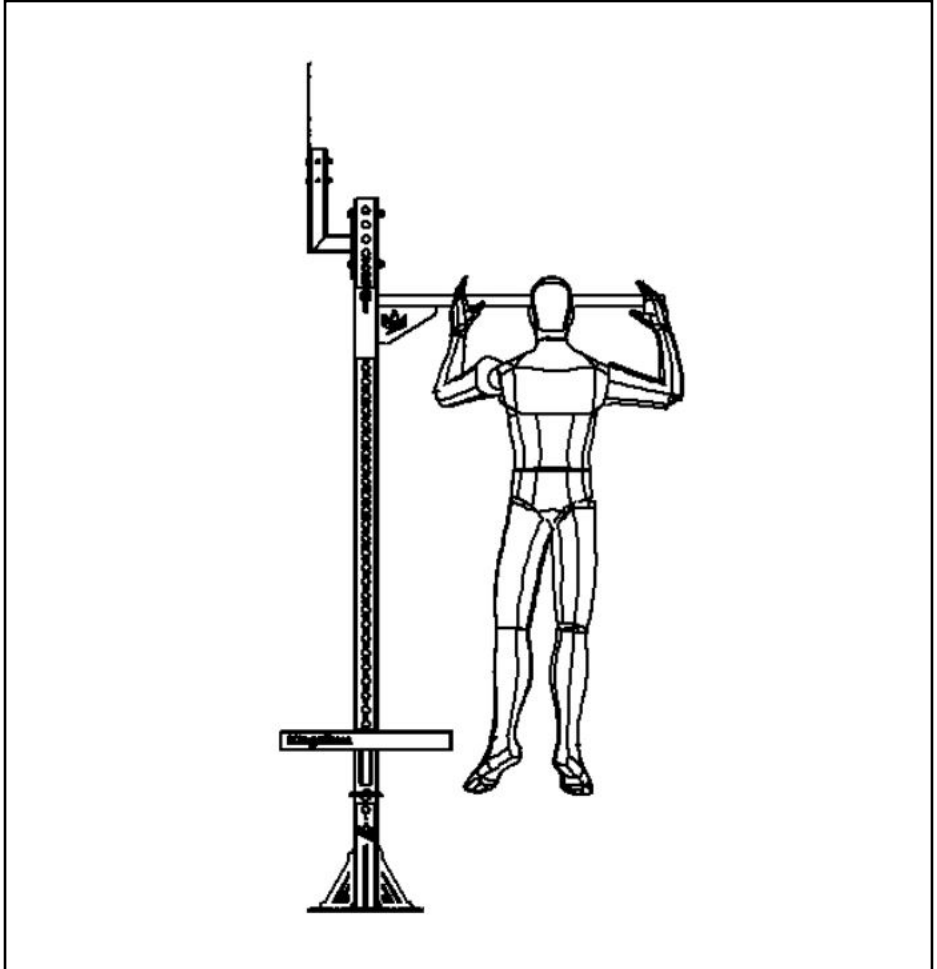

**LES ENFANTS NON SURVEILLÉS NE DEVRAIENT PAS S'APPROCHER DE L'ÉQUIPEMENT.**

# Instructions d'exercices

---

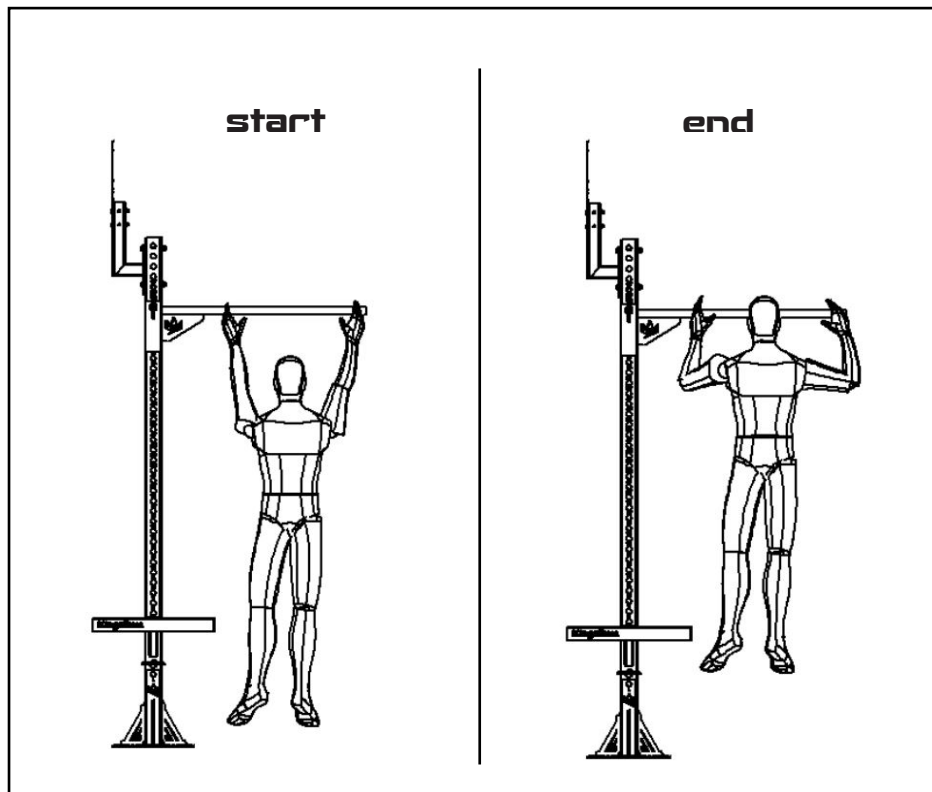

**UN ENTRAÎNEMENT EXCESSIF PEUT ENTRAÎNER  
DES PROBLÈMES DE SANTÉ ET DES BLESSURES.**

# Informations techniques

---

**Poids: 140 KG**

**Poids maximum de l'utilisateur : 100 KG**

**Capacité de charge maximale : 250 KG**

## **ATTENTION!**

**SI L'UN DES DISPOSITIFS DE RÉGLAGE (LEVIERS, ETC.) EST LAISSÉ EN SAILLIE, IL POURRAIT INTERFÉRER AVEC LES MOUVEMENTS DE L'UTILISATEUR.**

## **ATTENTION!**

**L'ÉQUIPEMENT AUTOPORTANT DOIT ÊTRE INSTALLÉ SUR UNE BASE STABLE ET NIVELÉE.**

## Dimensions

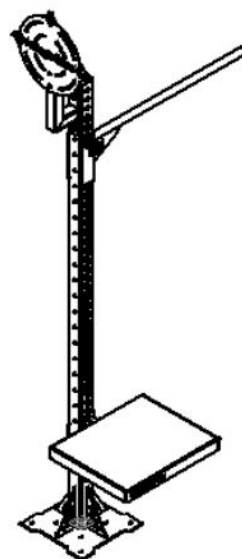
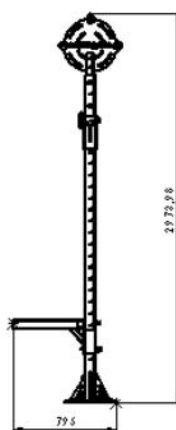
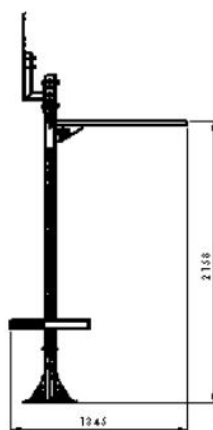

## **ATTENTION!**

**Si la structure n'est pas fixée au sol et/ou au mur, elle peut se renverser et/ou causer des dommages aux personnes ou aux objets à proximité immédiate.**

**Les boulons de fixation pour mur et/ou sol ne sont pas inclus dans le pack, car différents types de boulons d'ancrage doivent être utilisés pour différents types de mur/sol.**

# Soins et entretien

---

## **ATTENTION!**

**La sécurité de l'équipement n'est assurée qu'à la condition qu'il soit soigneusement inspecté pour détecter tout signe de dommage et/ou d'usure toutes les deux semaines.**

**Remplacez immédiatement les composants défectueux et usés ou mettez l'équipement hors service.**

**Le matériel doit toujours être maintenu propre et exempt de poussière, dans le respect de bonnes pratiques d'hygiène, surtout s'il est utilisé dans une salle de sport ou par plusieurs personnes.**

**Pour nettoyer les pièces rembourrées, utilisez un chiffon humide ou une éponge et un savon doux.**

**Chaque semaine, nettoyez les parties extérieures de l'équipement à l'aide d'une éponge humide.**

## **ATTENTION!**

**Veillez à ne pas froter avec une force excessive sur les dessins et les instructions figurant sur les étiquettes.**

# Liste des outils nécessaires

---

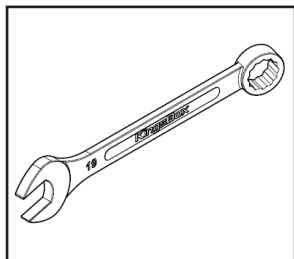

19 mm Wrench	2x
--------------	----

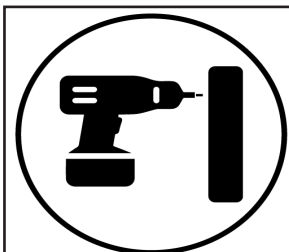

Drill	1x
-------	----

# Éléments d'assemblage

<b>SAMPLE</b>	
<div style="border: 1px solid black; width: 100px; height: 30px; margin: 0 auto; display: flex; align-items: center; justify-content: center;">             PICTURE           </div>	
<b>position</b>	<b>QTY.</b>
<b>name</b>	

	
<b>position 1</b>	<b>1x</b>
<b>Studio Upright 2750 F</b>	

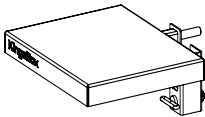
	
<b>position 2</b>	<b>1x</b>
<b>Mighty Plyo Platform</b>	

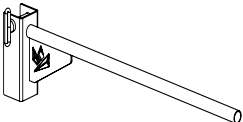
	
<b>position 3</b>	<b>1x</b>
<b>Start UP Bar F</b>	

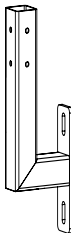
	
<b>position 4</b>	<b>1x</b>
<b>WB II. Holder S</b>	

	
<b>position 5</b>	<b>1x</b>
<b>WB Target III</b>	



# Éléments d'assemblage

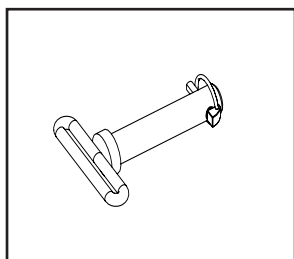

**position A** | **2x**

**Pin Bolt**

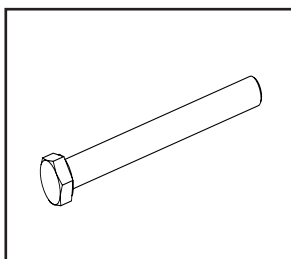

**position B** | **2x**

**M12x110**

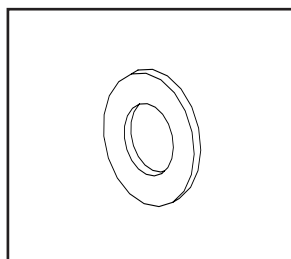

**position C** | **4x**

**Washer M12**

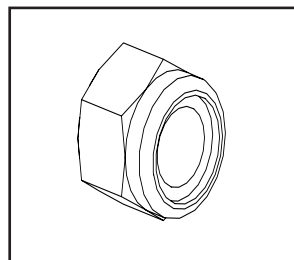

**position D** | **2x**

**Nut M12**

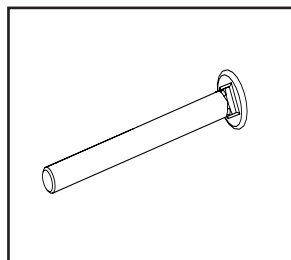

**position E** | **2x**

**M8x80 Torban**

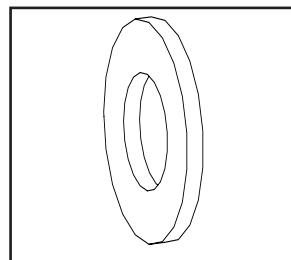

**position F** | **2x**

**Washer M8**

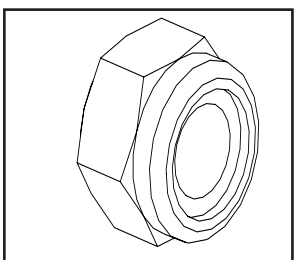

**position G** | **2x**

**Nut M8**

# Instructions de montage

## STEP 1

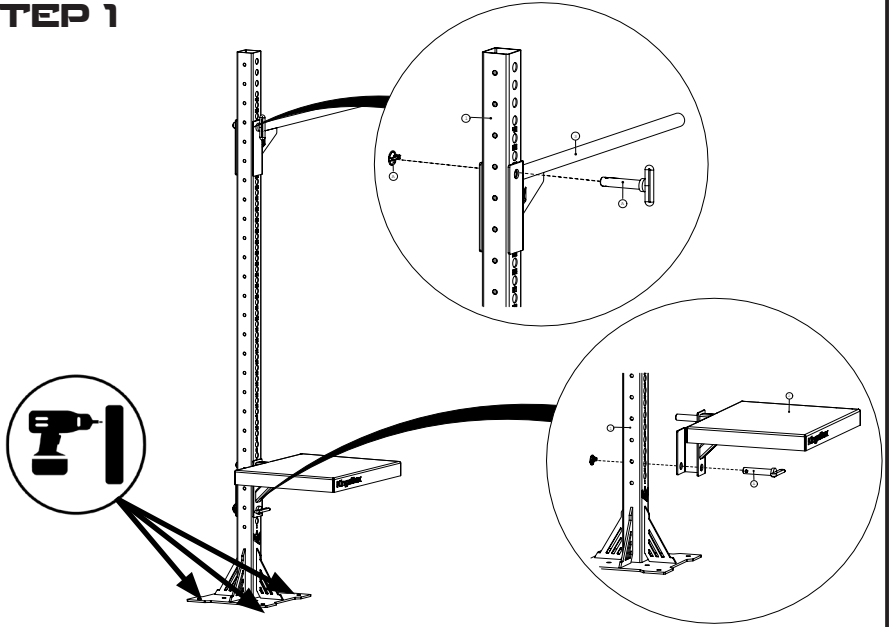

## STEP 2

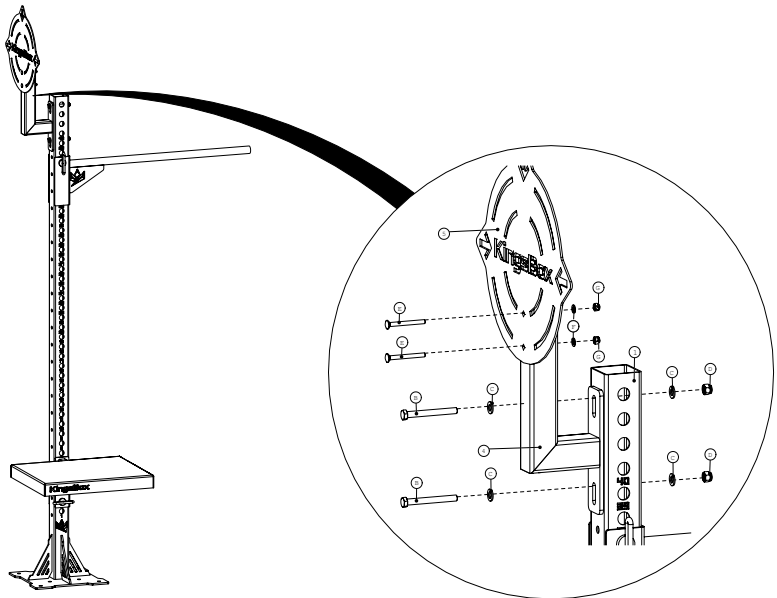

**DE**

# One Person Gym

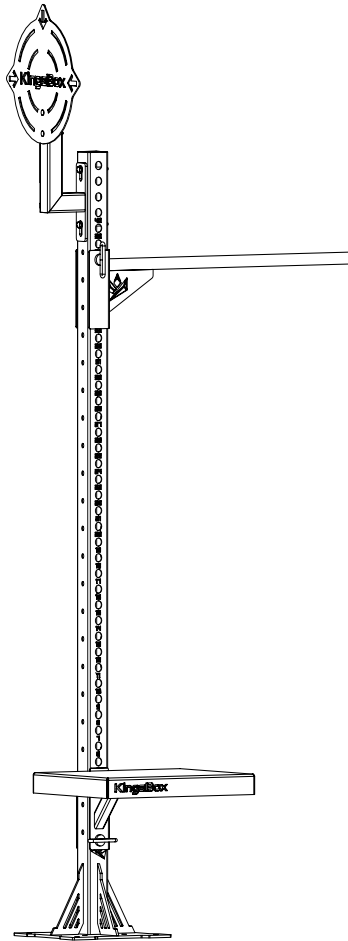

**KingsBox<sup>®</sup>**

**BUILDING BETTER HUMANS**

# **Inhaltsverzeichnis**

---

<b>Herstellerinformationen.....</b>	<b>48</b>
<b>Geräteidentifikation.....</b>	<b>48</b>
<b>Anwendungsgebiet.....</b>	<b>49</b>
<b>Anwendungsgebiet.....</b>	<b>50</b>
<b>Richtige Nutzung.....</b>	<b>51</b>
<b>Übungsanweisungen.....</b>	<b>52</b>
<b>Technische Informationen.....</b>	<b>53</b>
<b>Pflege und Wartung.....</b>	<b>55</b>
<b>Liste der erforderlichen Werkzeuge.....</b>	<b>56</b>
<b>Montageelemente.....</b>	<b>57</b>
<b>Montageanleitung.....</b>	<b>59</b>

# Herstellerinformationen

---

**TNG oprema d.o.o.**  
**Bazoviška cesta 7a, 6210 Sežana**  
**Slowenien**

**Kundenservice**

**Telefonnummer: +386 18 28 08 97**

**E-Mail: info@kingsbox.it**

**Adresse: Bazoviška cesta 7a, 6210 Sežana**  
**Slowenien**

# Geräteidentifikation

---



# **Anwendungsgebiet**

---

**Klassifizierung::**

**EN ISO 20957-1:2013 Class S**

**Der freie Bereich, von dem aus das Trainingsgerät betreten wird, darf nicht kleiner als 0,6 m in jede Richtung vom Gerät aus sein. In dem freien Bereich muss auch genügend Platz für Rettungsmaßnahmen berücksichtigt werden. Sollten mehrere Geräte nebeneinanderstehen, dann kann der Bereich pro Gerät geteilt werden. Die Möglichkeit, dass die Nutzer das Gerät gemäß diesem Handbuch nicht verwenden können, ist zu vermeiden.**

# Gerätepositionierung

Grundfläche (foot print):

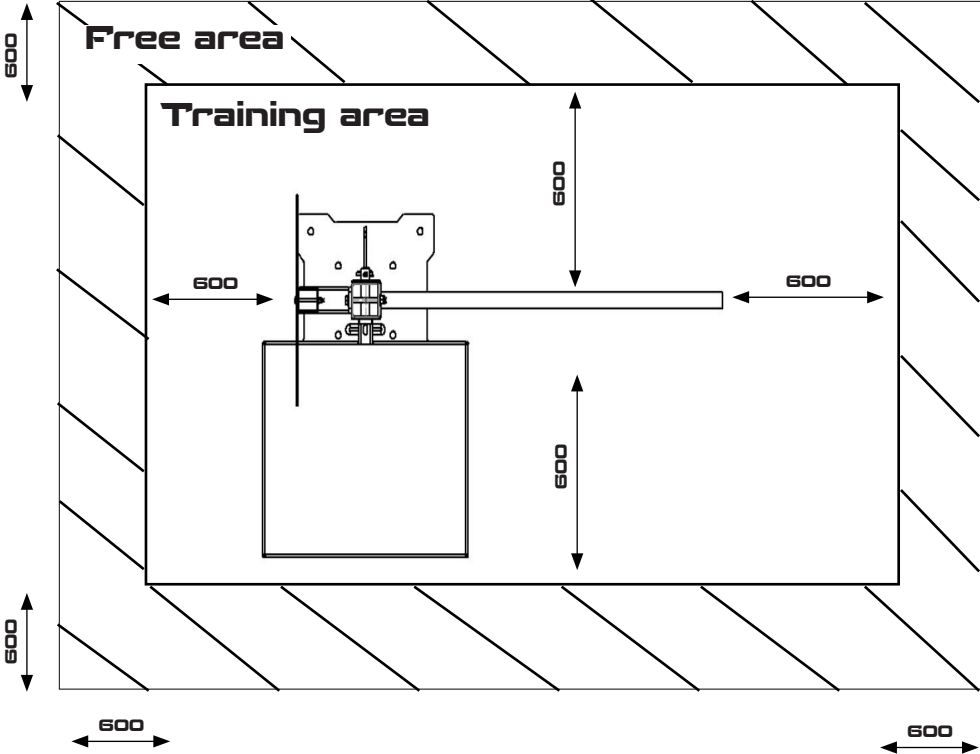

# Richtige Nutzung

---

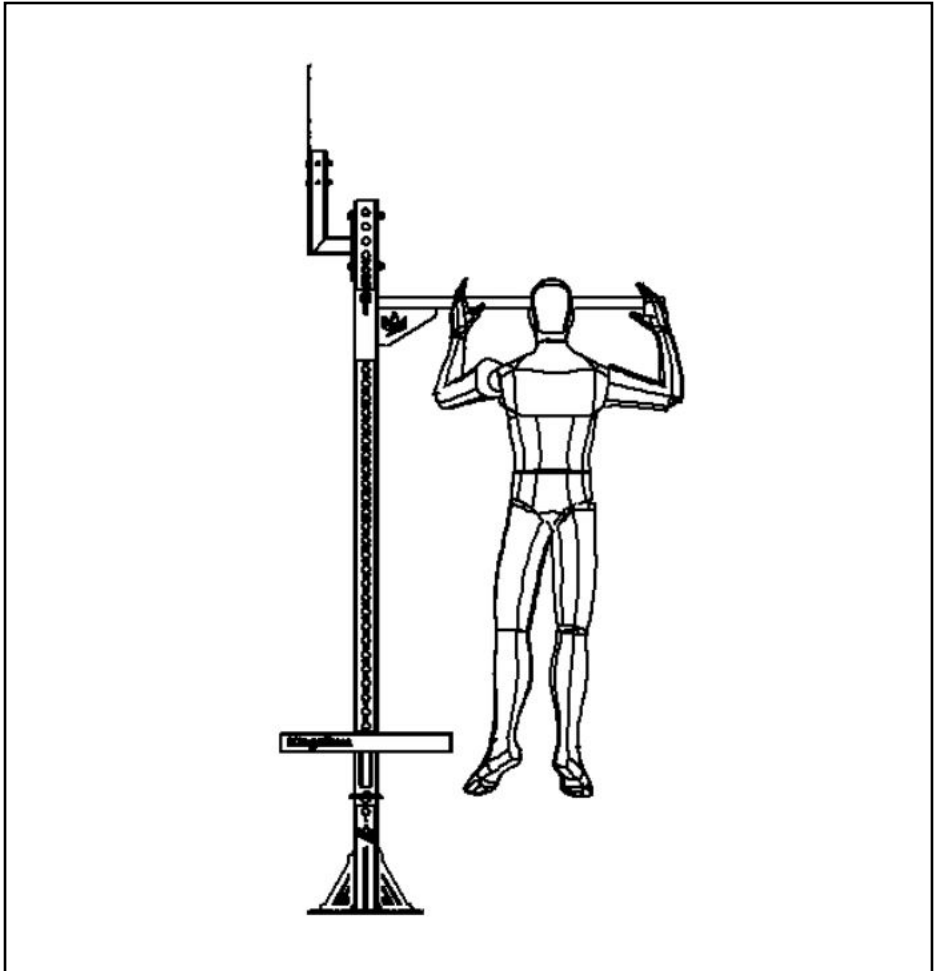

Kinder nicht unbeaufsichtigt in die Nähe der Trainingsgeräte lassen.



# Übungsanweisungen

---

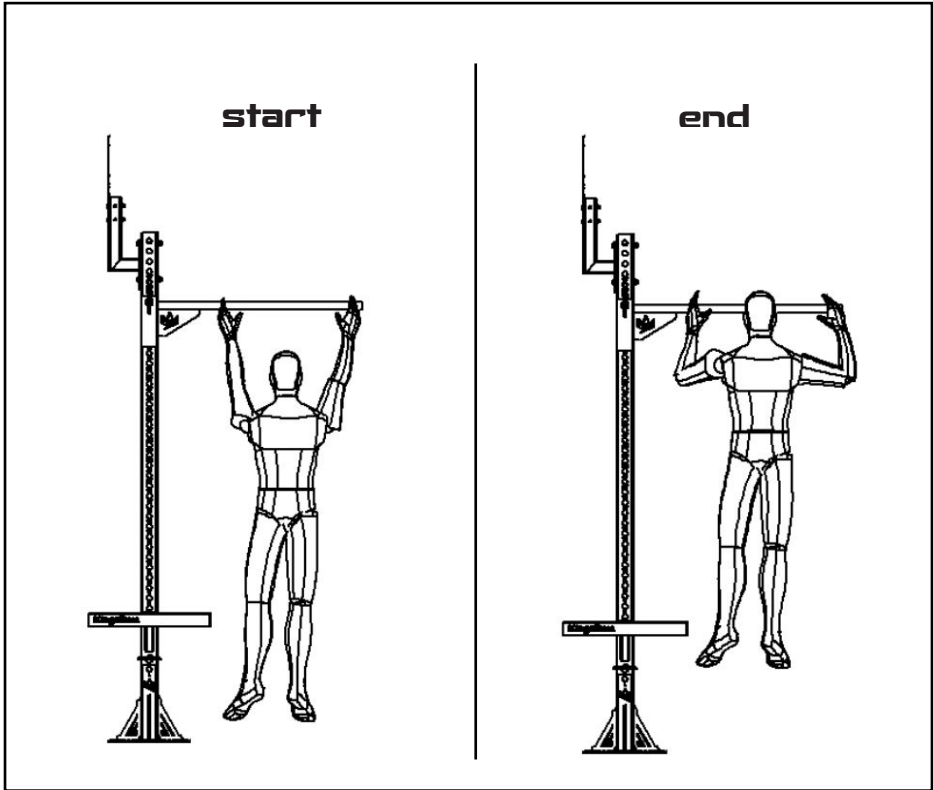

**Übermäßiges Training kann zu gesundheitlichen Problemen und Verletzungen führen.**

# **Technische Informationen:**

---

**Gewicht: 16 KG**

**Maximales Nutzergewicht: 100 KG**

**Maximale Belastbarkeit: 250 KG**

## **ACHTUNG!**

**Sollte eine der Einstellvorrichtungen (Hebel usw.) herausragen, dann kann es zur Beeinträchtigung der Bewegung des Nutzers kommen.**

## **ACHTUNG!**

**Freistehende Geräte sollten auf einem stabilen und ebenen Untergrund aufgebaut werden!**

## Dimensions

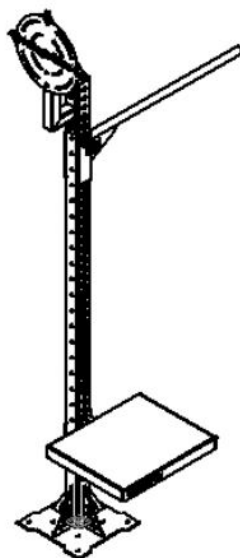
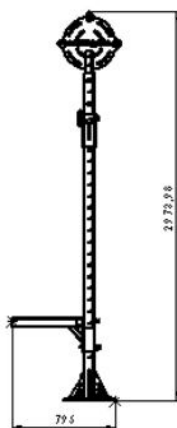
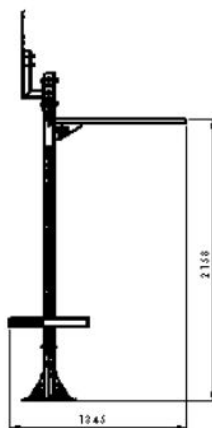

## **ACHTUNG!**

**Sollte das Gerät nicht am Boden oder an der Wand befestigt werden, dann kann es umkippen und Personen oder Gegenstände in der unmittelbaren Nähe beschädigen**

**Das benötigte Befestigungsmaterial für Wand und Boden sind nicht im Lieferumfang enthalten. Das Befestigungsmaterial ist je nach Wand- oder Bodentyp auszuwählen.**

# Pflege und Wartung

---

## **ACHTUNG!**

**Die Sicherheit des Gerätes ist nur unter regelmäßiger Kontrolle (alle zwei Wochen) auf Beschädigungen oder Verschleiß des Gerätes gewährleistet.**

**Defekte und abgenutzte Komponenten müssen sofort ersetzt werden oder das Gerät muss alternativ außer Betrieb genommen werden.**

Entsprechend einer guten Hygiene sollte das Gerät sauber und staubfrei gehalten werden, besonders wenn es von mehr als einer Person verwendet wird.

Zur Reinigung der gepolsterten Teile sollte ein feuchtes Tuch oder ein Schwamm mit mildem Reinigungsmittel verwendet werden.

Reinigen Sie die Außenteile des Gerätes jede Woche mit einem feuchten Schwamm.

## **ACHTUNG!**

**Achten Sie darauf, dass Sie nicht mit übermäßiger Kraft über die Zeichnungen und Anweisungen auf den Etiketten reiben.**

# Liste der erforderlichen Werkzeuge

---

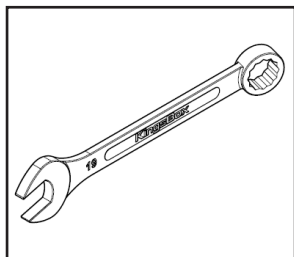

19 mm Wrench	2x
--------------	----

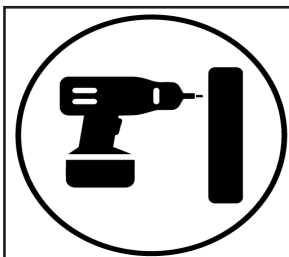

Drill	1x
-------	----

# Montageelemente

<b>SAMPLE</b>	
<div style="border: 1px solid black; padding: 5px; width: fit-content; margin: 0 auto;">             PICTURE           </div>	
<b>position</b>	<b>QTY.</b>
<b>name</b>	

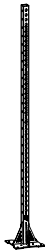
	
<b>position 1</b>	<b>1x</b>
<b>Studio Upright 2750 F</b>	

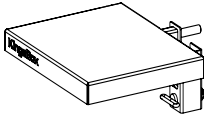
	
<b>position 2</b>	<b>1x</b>
<b>Mighty Plyo Platform</b>	

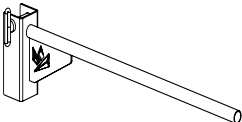
	
<b>position 3</b>	<b>1x</b>
<b>Start UP Bar F</b>	

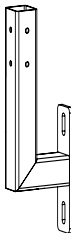
	
<b>position 4</b>	<b>1x</b>
<b>WB II. Holder S</b>	

	
<b>position 5</b>	<b>1x</b>
<b>WB Target III</b>	

# Montageelemente

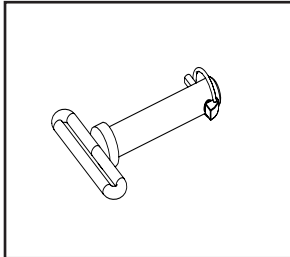

<b>position A</b>	<b>2x</b>
<b>Pin Bolt</b>	

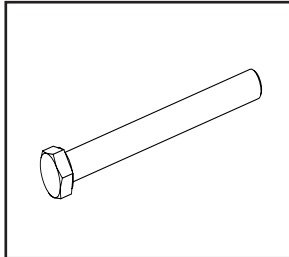

<b>position B</b>	<b>2x</b>
<b>M12x110</b>	

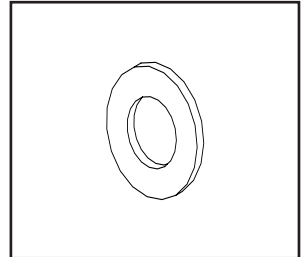

<b>position C</b>	<b>4x</b>
<b>Washer M12</b>	

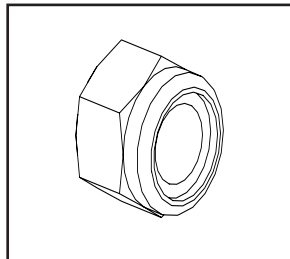

<b>position D</b>	<b>2x</b>
<b>Nut M12</b>	

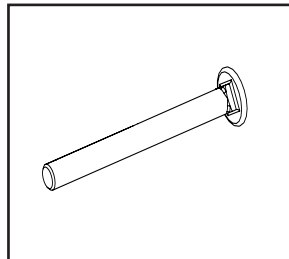

<b>position E</b>	<b>2x</b>
<b>M8x80 Torban</b>	

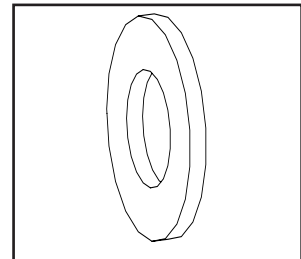

<b>position F</b>	<b>2x</b>
<b>Washer M8</b>	

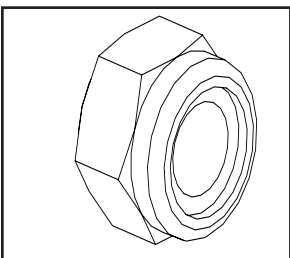

<b>position G</b>	<b>2x</b>
<b>Nut M8</b>	

# Montageanleitung

## STEP 1

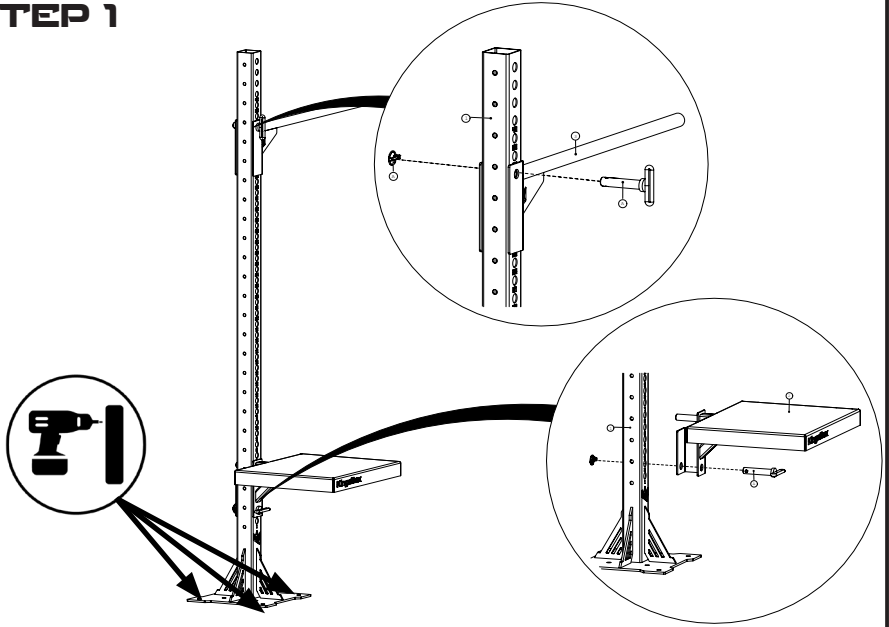

## STEP 2

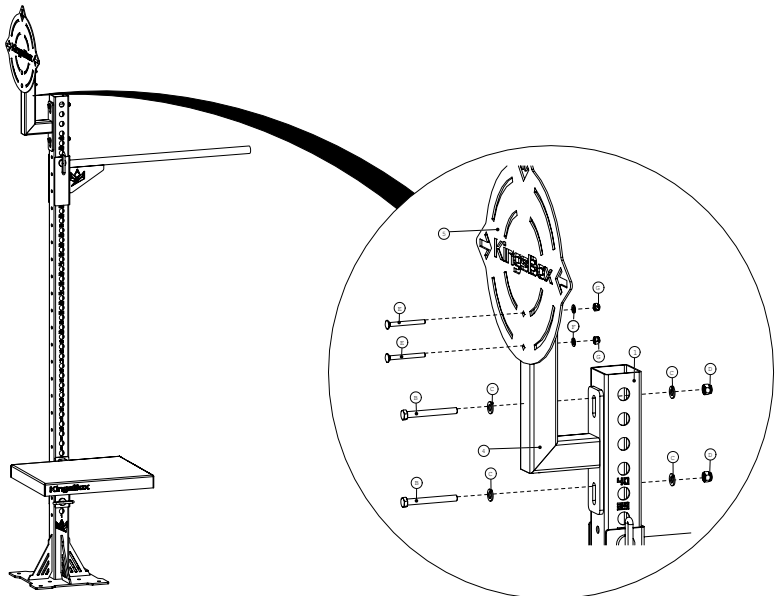



# SLO

## One Person Gym

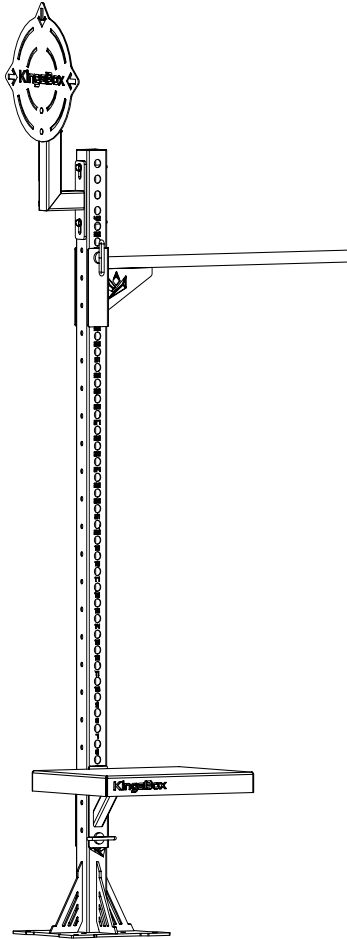

# KingsBox<sup>®</sup>

BUILDING BETTER HUMANS

# Kazalo vsebine

---

<b>Podatki o proizvajalcu.....</b>	<b>63</b>
<b>Identifikacija izdelka.....</b>	<b>63</b>
<b>Uporabnost.....</b>	<b>64</b>
<b>Postavitev izdelka.....</b>	<b>65</b>
<b>Pravilna uporaba izdelka.....</b>	<b>66</b>
<b>Navodila za izvajanje vaje.....</b>	<b>67</b>
<b>Tehnične informacije.....</b>	<b>68</b>
<b>Nega in vzdrževanje.....</b>	<b>70</b>
<b>Seznam potrebnih orodij.....</b>	<b>71</b>
<b>Seznam sestavnih delov.....</b>	<b>72</b>
<b>Navodila za montažo.....</b>	<b>74</b>

## Podatki o proizvajalcu

---

TNG oprema d.o.o.  
Bazoviška cesta 7a, 6210 Sežana  
Slovenija

Podpora strankam

Telefon: +386 18 28 08 97

E-mail: [info@kingsbox.it](mailto:info@kingsbox.it)

Naslov: Bazoviška cesta 7a, 6210 Sežana  
Slovenija

## Identifikacija izdelka

---



# Uporabnost

---

**Klasifikacija izdelka:**

**EN ISO 20957-1:2013 Class S**

**Prosto območje okrog območja za trening ne bi smelo biti manjše od 0,6 m v vseh smereh. Prosto območje mora vključevati tudi območje za urgentni dostop ali sestop. Če je več izdelkov nameščenih eden zraven drugega, si lahko delijo prosto območje.**

# Umestitev izdelka

Tloris izdelka (foot print):

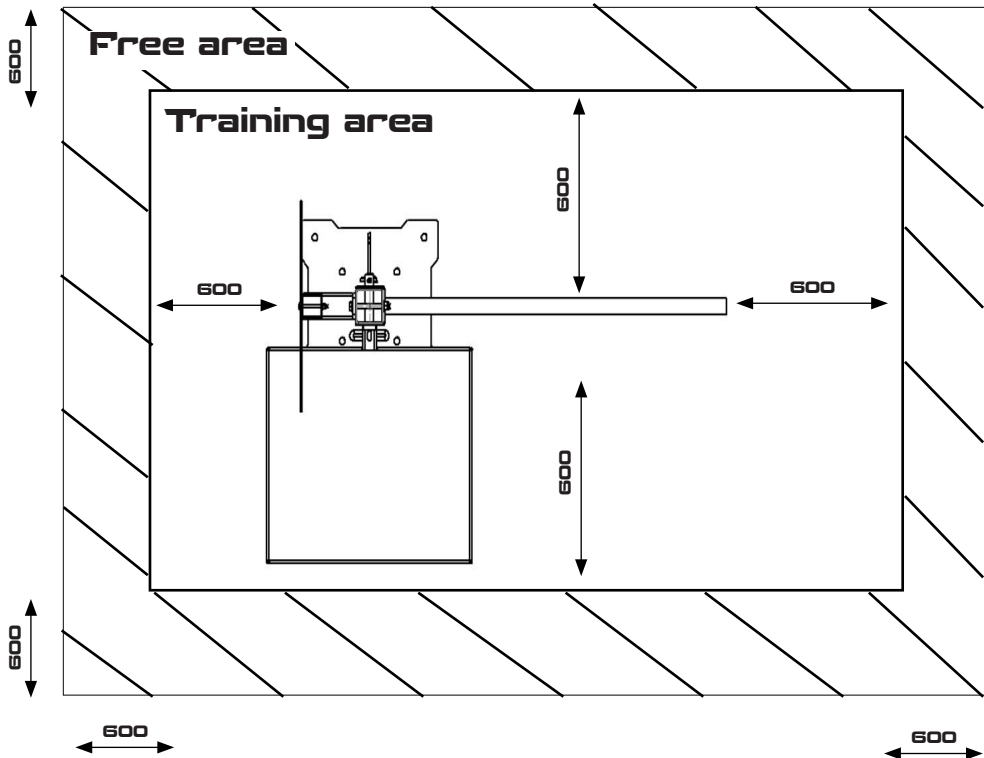

# Pravilna uporaba izdelka

---

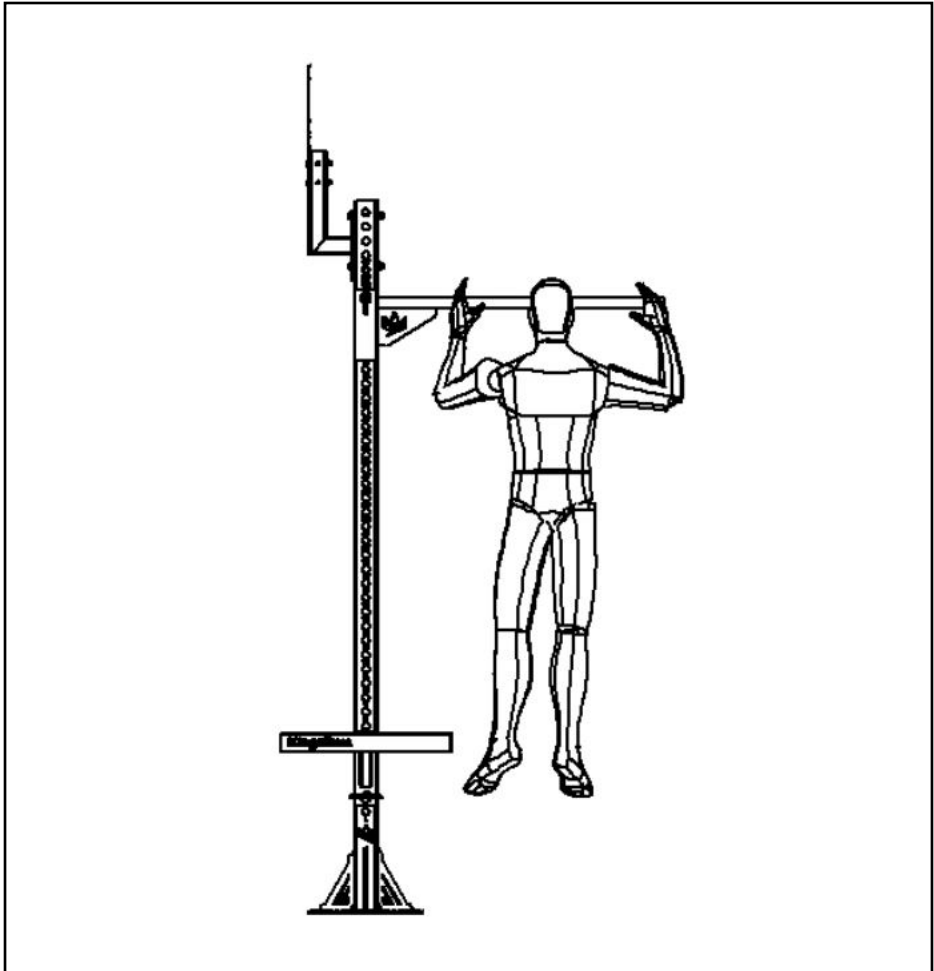

**Nikoli ne dovolite, da se otroci nenadzorovano igrajo ali vadijo na napravi.**

# Navodila za izvajanje vaje

---

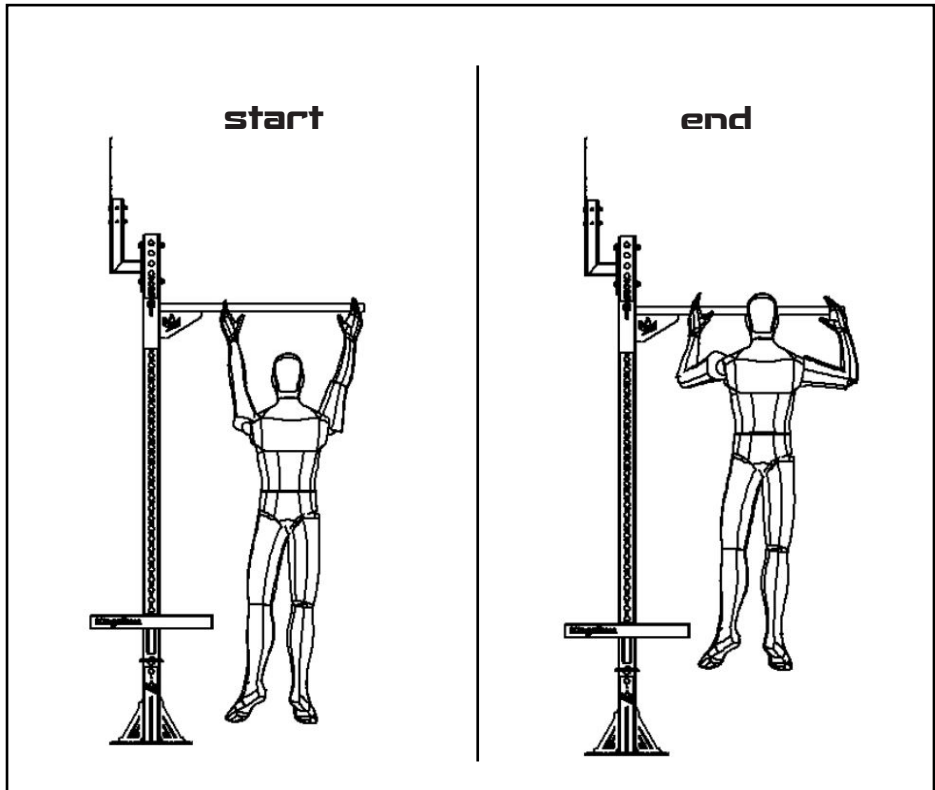

**Pretirana vadba ali nepravilna uporaba lahko vodita do poškodb.**

# **Tehnične informacije**

---

**Masa izdelka: 140 KG**

**Največja dovoljena masa uporabnika: 100 KG**

**Največja obremenitev: 250 KG**

## **Pozor!**

**Če naprava, ki ima možnost nastavljanja, ostane v položaju, ki ni nevtralen, lahko to ovira gibanje uporabnika.**

## **Pozor!**

**Prostostoječi izdelki morajo biti nameščeni na ravni in stabilni podlagi.**



## Dimenzije

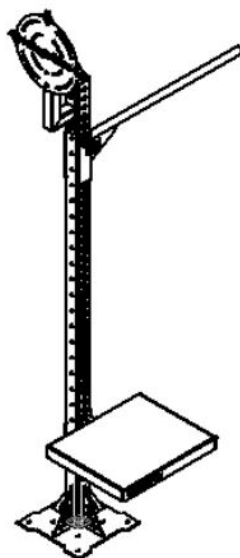
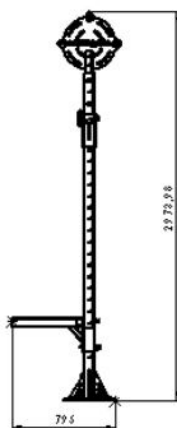
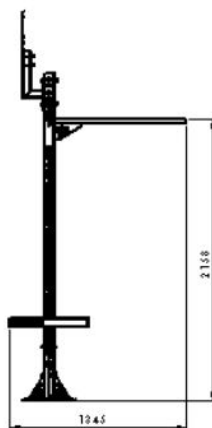

## **Pozor!**

**V kolikor struktura ni pričvrščena v tla in/ali na steno, se lahko prevrne in/ali povzroči škodo predmetom v bližini, vadečemu ali osebam v neposredni bližini.**

**Vijaki za pričvrščevanje niso vključeni v paket, saj za različne stene/tla potrebujemo drugačne vijake.**

# Nega in vzdrževanje

---

## **POZOR!**

**Varnost opreme je zagotovljena le pod pogojem, da je vsaka dva tedna pregledana za znake poškodb in/ali obrabe.**

**Poškodovane, uničene ali obrabljene sestavne dele takoj zamenjajte ali izdelek umaknite iz uporabe.**

Izdelke je potrebno vzdrževati čiste, vključno z brisanjem prahu, kar je v skladu z visokimi higienskimi standardi, katerim morajo slediti telovadnice ali studii, kjer opremo uporablja več kot ena oseba.

Za čiščenje oblazinjenih delov uporabite vlažno krpo ali gobico in nežno čistilno sredstvo.

Vsak teden očistite zunanje dele izdelka z vlažno krpo.

## **POZOR!**

**Pazite, da s krpo ali čistili ne drgnete pregrebo po nalepkah na izdelku.**

# Seznam potrebnih orodij

---

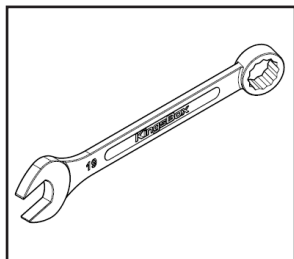

19 mm Wrench	2x
--------------	----

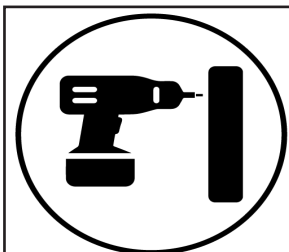

Drill	1x
-------	----

# Seznam sestavnih delov

<b>SAMPLE</b>	
<div style="border: 1px solid black; padding: 5px; width: fit-content; margin: 0 auto;">             PICTURE           </div>	
<b>position</b>	<b>QTY.</b>
<b>name</b>	

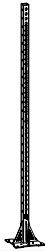
	
<b>position 1</b>	<b>1x</b>
<b>Studio Upright 2750 F</b>	

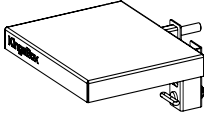
	
<b>position 2</b>	<b>1x</b>
<b>Mighty Plyo Platform</b>	

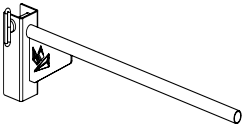
	
<b>position 3</b>	<b>1x</b>
<b>Start UP Bar F</b>	

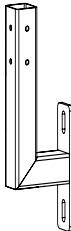
	
<b>position 4</b>	<b>1x</b>
<b>WB II. Holder S</b>	

	
<b>position 5</b>	<b>1x</b>
<b>WB Target III</b>	

# Seznam sestavnih delov

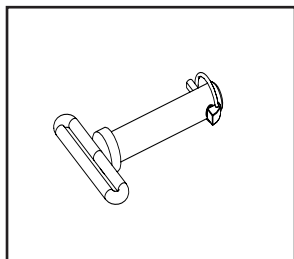

<b>position A</b>	<b>2x</b>
<b>Pin Bolt</b>	

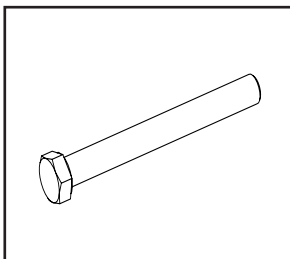

<b>position B</b>	<b>2x</b>
<b>M12x110</b>	

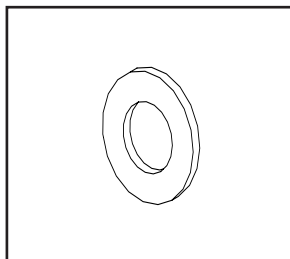

<b>position C</b>	<b>4x</b>
<b>Washer M12</b>	

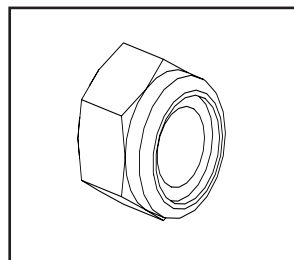

<b>position D</b>	<b>2x</b>
<b>Nut M12</b>	

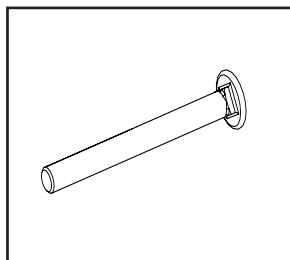

<b>position E</b>	<b>2x</b>
<b>M8x80 Torban</b>	

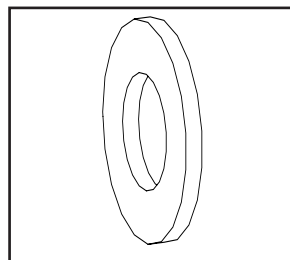

<b>position F</b>	<b>2x</b>
<b>Washer M8</b>	

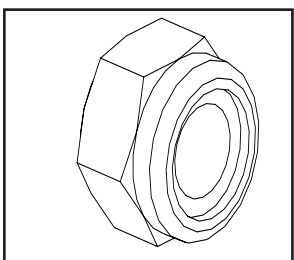

<b>position G</b>	<b>2x</b>
<b>Nut M8</b>	

# Navodila za montažo

## STEP 1

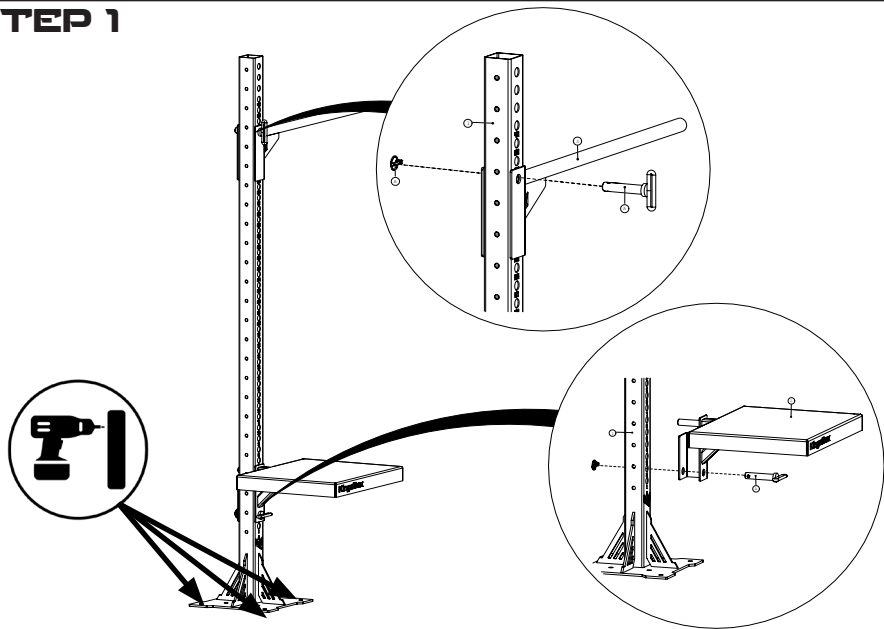

## STEP 2

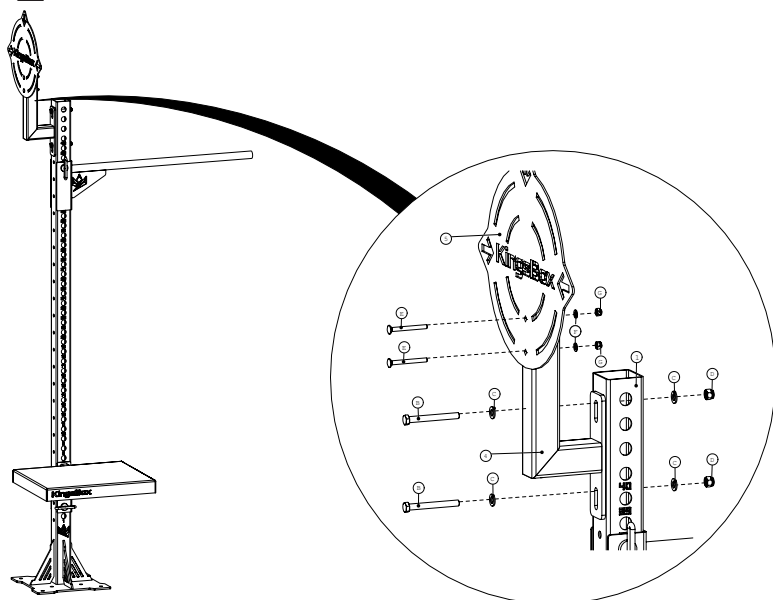

**HR**

# One Person Gym

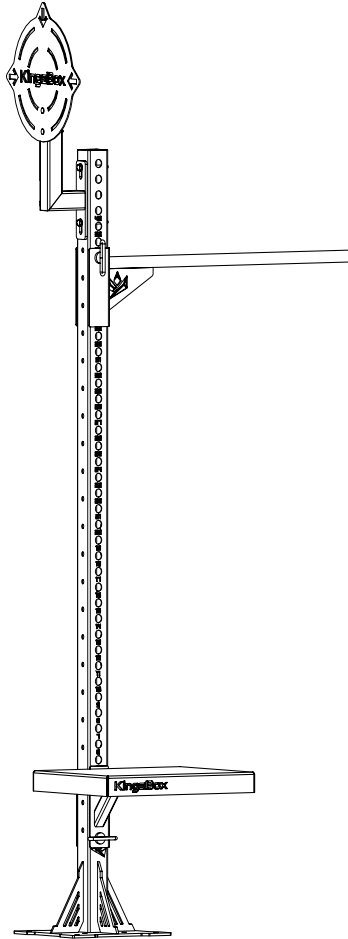

**KingsBox®**

**BUILDING BETTER HUMANS**

# Sadržaj

---

Podaci o proizvođaču.....	73
Identifikacija opreme.....	73
Područje primjene.....	74
Pozicioniranje opreme.....	75
Ispravna uporaba opreme.....	76
Upute za vježbu.....	77
Tehničke informacije.....	78
Njega i održavanje.....	80
Popis potrebnih alata.....	81
Elementi montaže.....	82
Upute za montažu.....	84



# Podaci o proizvođaču

---

**TNG oprema d.o.o.**  
**Bazoviška cesta 7a, 6210 Sežana**  
**Slovenija**

**Služba za korisnike**

**Telefon: +386 18 28 08 97**

**E-mail: info@kingsbox.it**

**Adresa: Bazoviška cesta 7a, 6210 Sežana**  
**Slovenija**

# Identifikacija opreme

---



# Područje primjene

---

## **Klasifikacija proizvoda: EN ISO 20957-1:2013 Class S**

**Slobodan prostor oko područja namjenjenog za treniranje ne bi smio biti manji od 0.6 m u svim smjerovima. Slobodan prostor bi također trebao imati pristup izazlu u slučaju nužde. Ukoliko se nekoliko proizvoda nalaze jedan pokraj drugog, mogu dijeliti slobodan prostor.**

# Pozicioniranje opreme

Ukupna površina (foot print):

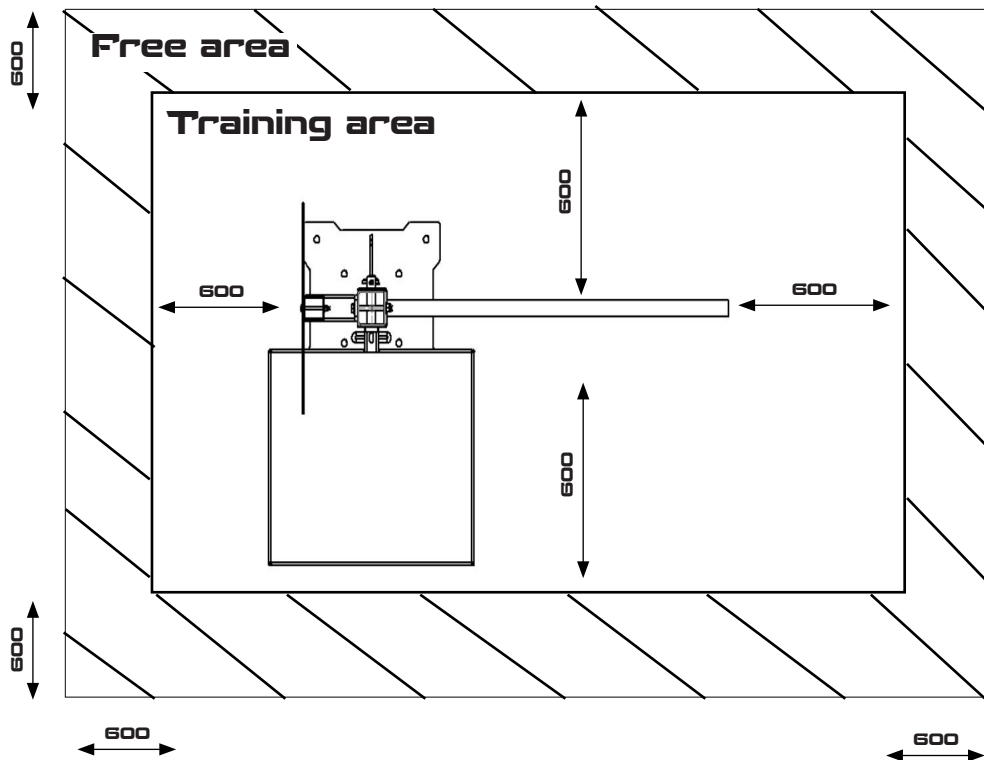

# Ispravna uporaba opreme

---

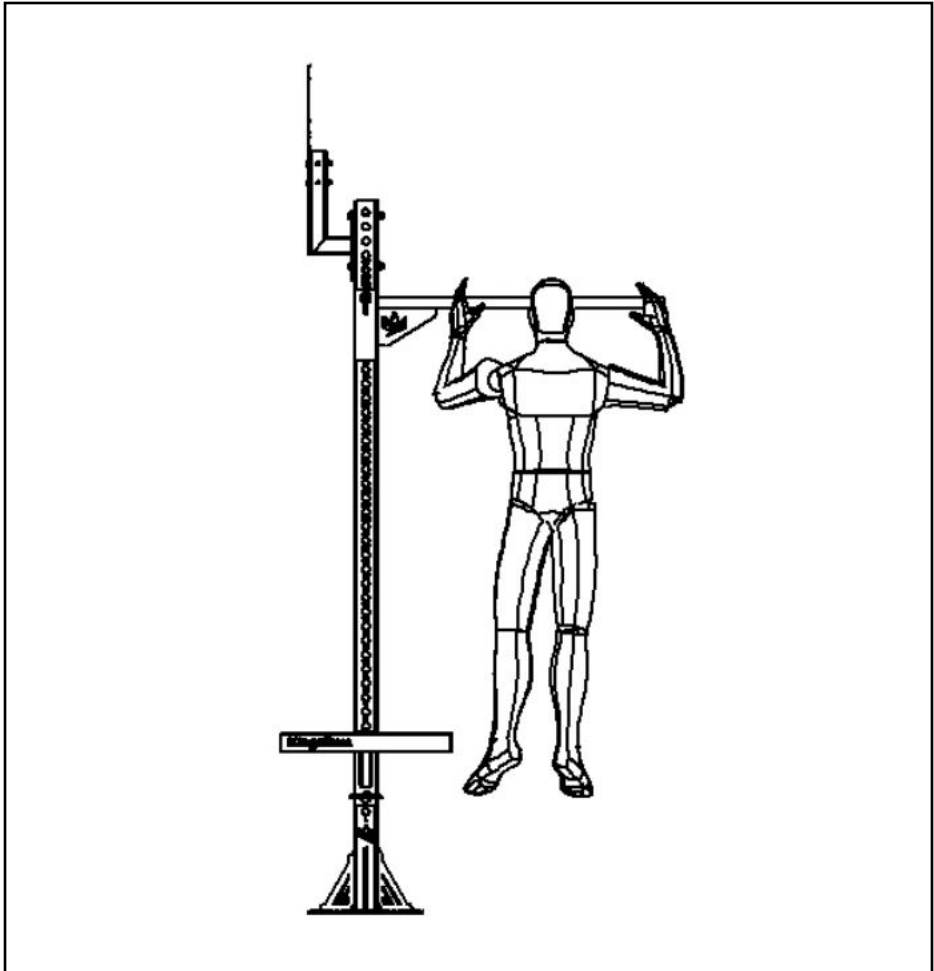

**Djeca bez nadzora ne bi smjela imati pristup opremi.**

# Upute za vježbu

---

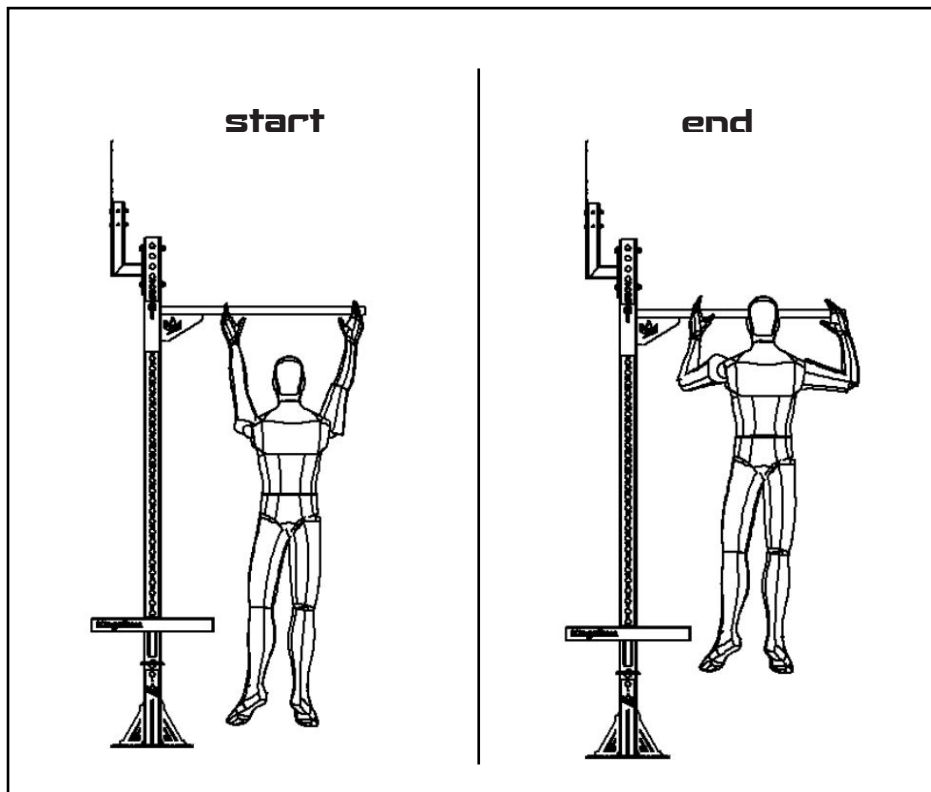

**Prekomjerno treniranje može rezultirati problemima sa zdravljem ili ozljedama.**

# **Tehničke informacije**

---

**Težina: 140 KG**

**Maksimalna težina korisnika: 100 KG**

**Maksimalno opterećenje: 250 KG**

## **UPOZORENJE!**

**Ako bilo koji od uređaja za podešavanje (poluge itd.) ne sjedne u svoj položaj, npr. strše van svog prirodnog položaja, mogao bi ometati kretanje korisnika.**

## **UPOZORENJE!**

**Samostojeća oprema trebala bi biti postavljena na ravnu i stabilnu površinu!**

## Dimensions

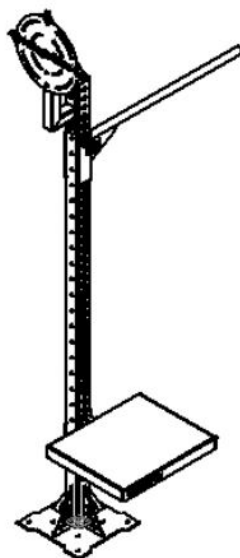
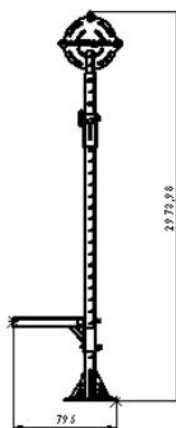
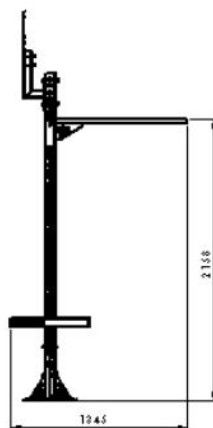

## UPOZORENJE!

**Ako konstrukcija nije pričvršćena za tlo i / ili zid, može se prevrnuti i / ili nanijeti štetu osobi ili predmetu u neposrednoj blizini.**

**Vijci za pričvršćivanje za zid i / ili pod nisu uključeni u doba pakiranja, jer se za različite tipove zida / poda moraju koristiti različite vrste vijaka.**

# Njega i održavanje

---

## **UPOZORENJE!**

**Sigurnost opreme osigurana je samo pod uvjetom da se svaka dva tjedna pažljivo pregledava na znakove oštećenja i / ili habanja.**

**Odmah zamijenite neispravne i istrošene dijelove ili uklonite opremu iz upotrebe.**

**Oprema uvijek treba biti čista i bez prašine, u skladu s dobrom higijenskom praksom, posebno ako se koristi u teretani ili ako ju koristi više osoba.**

**Za čišćenje podstavljenih dijelova koristite vlažnu krpu ili spužvu i blagi sapun.**

**Svaki tjedan očistite vanjske dijelove opreme vlažnom spužvom.**

## **UPOZORENJE!**

**Pazite da pretjeranom silom ne trljate crteže i upute prikazane na naljepnicama.**



# Popis potrebnih alata

---

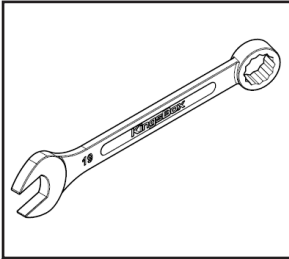

19 mm Wrench	2x
--------------	----

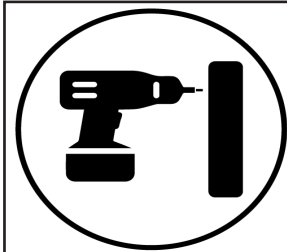

Drill	1x
-------	----

# Elementi montaže

<b>SAMPLE</b>	
<div style="border: 1px solid black; padding: 5px; width: fit-content; margin: 0 auto;">             PICTURE           </div>	
<b>position</b>	<b>QTY.</b>
<b>name</b>	

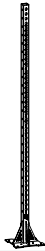
	
<b>position 1</b>	<b>1x</b>
<b>Studio Upright 2750 F</b>	

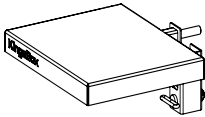
	
<b>position 2</b>	<b>1x</b>
<b>Mighty Plyo Platform</b>	

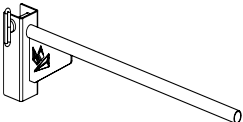
	
<b>position 3</b>	<b>1x</b>
<b>Start UP Bar F</b>	

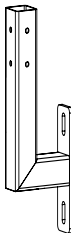
	
<b>position 4</b>	<b>1x</b>
<b>WB II. Holder S</b>	

	
<b>position 5</b>	<b>1x</b>
<b>WB Target III</b>	

# Elementi montaže

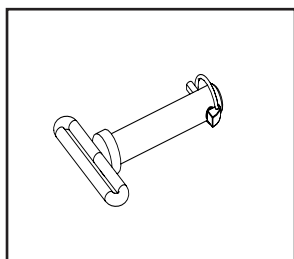

**position A** | **2x**

**Pin Bolt**

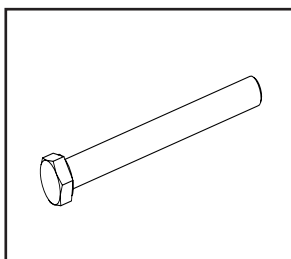

**position B** | **2x**

**M12x110**

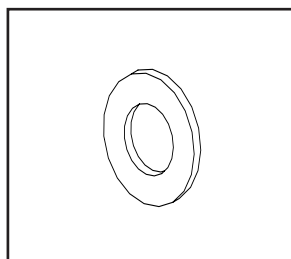

**position C** | **4x**

**Washer M12**

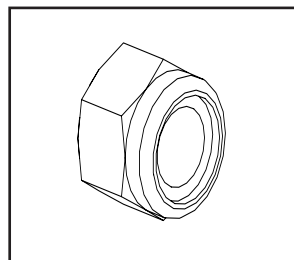

**position D** | **2x**

**Nut M12**

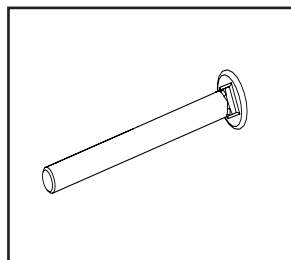

**position E** | **2x**

**M8x80 Torban**

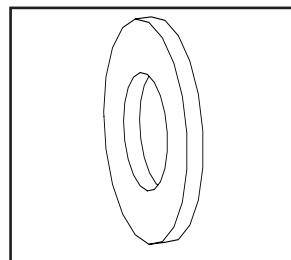

**position F** | **2x**

**Washer M8**

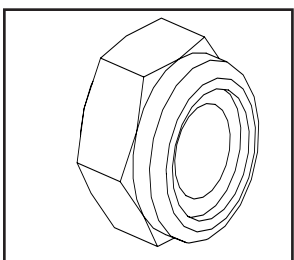

**position G** | **2x**

**Nut M8**

# Upute za montažu

## STEP 1

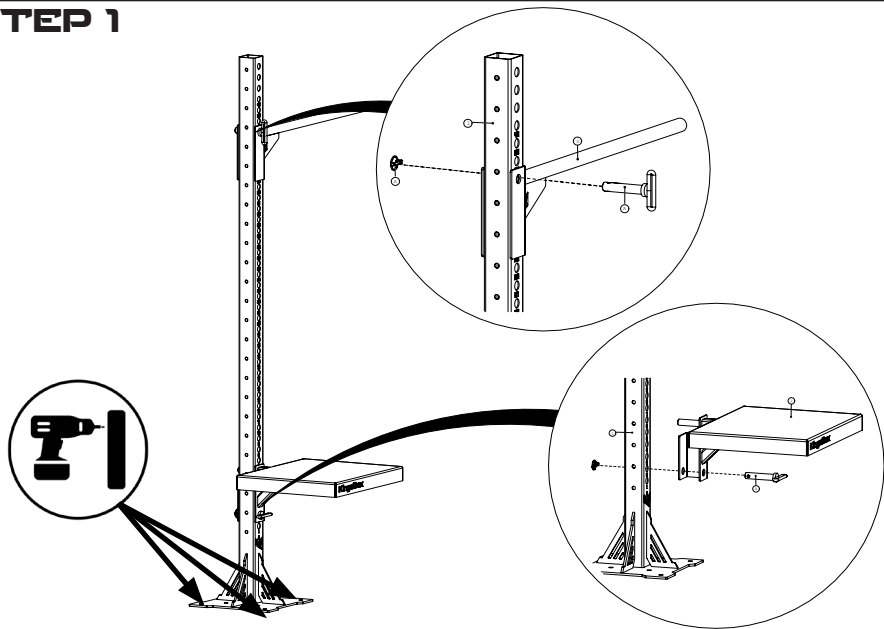

## STEP 2

