

Adj. Cable CrossOver

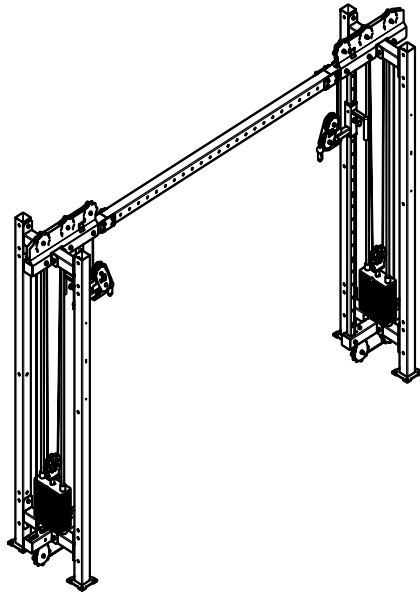

KingsBox[®]
BUILDING BETTER HUMANS

Bridge Tower (Adjustable Pulley)

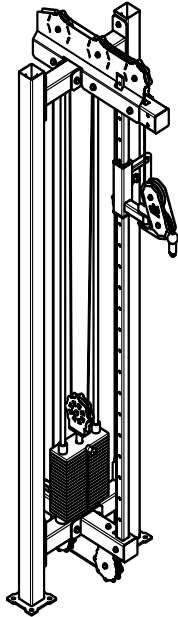

KingsBox®
BUILDING BETTER HUMANS

ATTENZIONE!

Se la struttura non viene fissata a terra e/o al muro, può rib-altarsi e/o provocare danni a persone o oggetti in immediata vicinanza.

I bulloni per il fissaggio del rig a muro e/o al pavimento non sono inclusi nel pacco, in quanto per diversi tipi di muro e pavimentazione bisogna utilizzare diversi tipi di bulloni d'ancoraggio.

OPOZORILO!

Če se struktura prevrne, lahko pride do resnih telesnih poškodb. Da bi preprečili nevarnost, da se ta struktura prevrne, mora biti pritrjena na steno in / ali v tla.

Vijaki za pritrjevanje strukture na steno oz. tla niso priloženi, saj različne sestave zidov oz. tal zahtevajo različne vrste pritrdilnih elementov. Uporabite take, ki ustrezajo sestavi vaše stene oz. tal.

WARNING!

If the structure is not secured to the ground and / or to the wall, it may overturn and / or cause damage to person or object in the immediate vicinity.

The fixing bolts for wall and / or floor are not included in the pack-age, since different types of anchor bolts must be used for different wall / floor types.

Assembly elements:

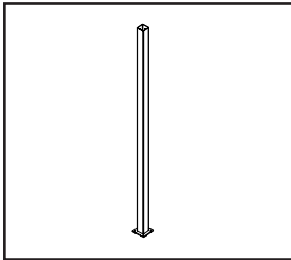

Position 1

**Pulley Tower
Upright**

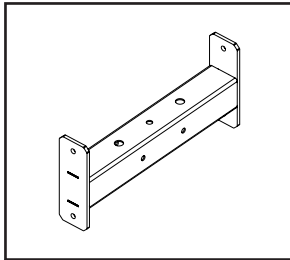

Position 2

**PT_connecting
profile_bottom**

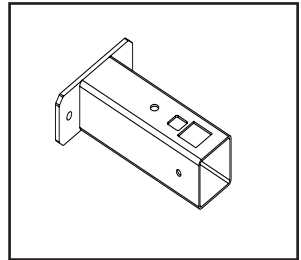

Position 3

**PT_Adj. profile
bottom**

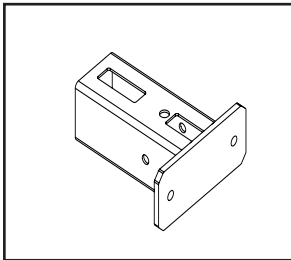

Position 4

PT_Universal profile

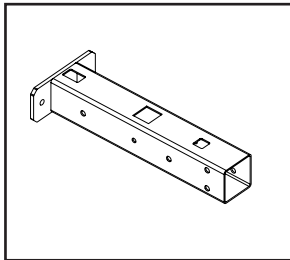

Position 5

PT_Adj. profile up

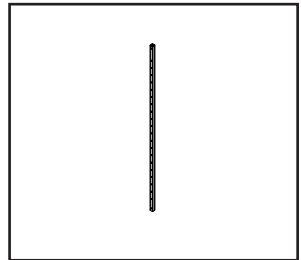

Position 6

**CCO Height Adj.
Column**

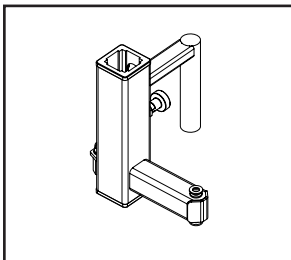

Position 7

**CCO Height Adj.
Trolley**

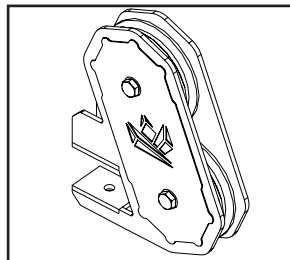

Position 8

CCO Pulley Cart

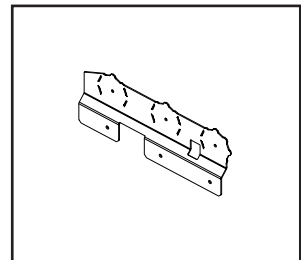

Position 9

**PT_Adj. Pulley
Plate_L**

Assembly elements:

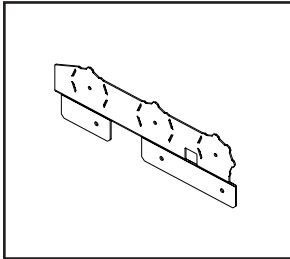

Position 10

**PT_Adj. Pulley
Plate_D**

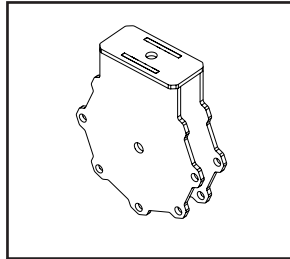

Position 11

**PT_Single Pulley
Holder**

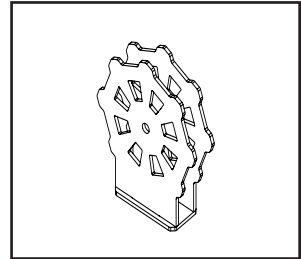

Position 12

**PT_Stack Pulley
Holder**

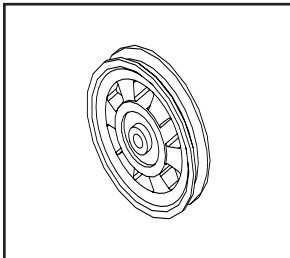

Position 13

Belt Pulley f114

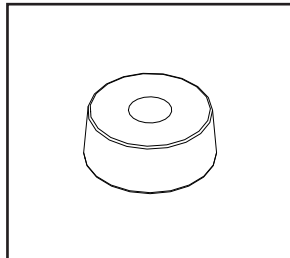

Position 14

WS_Rubber Cushion

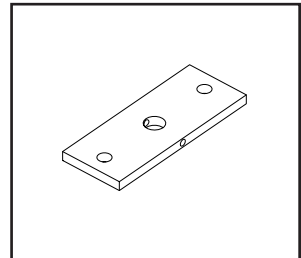

Position 15

WS-50 Weight Stack

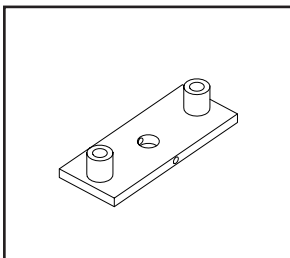

Position 16

WS-50_Top Plate

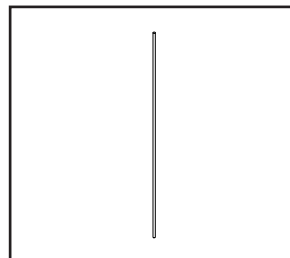

Position 17

WS_Guide Rod

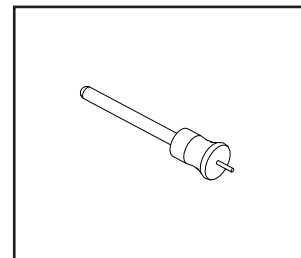

Position 18

WS_Pin

Assembly elements:

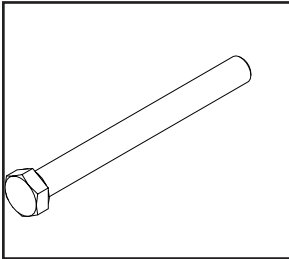

Position 19

M12x120

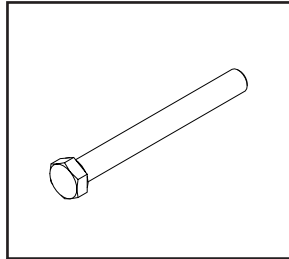

Position 20

M12x110

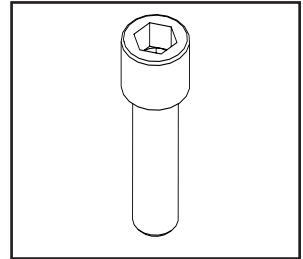

Position 21

M12x35 imbus

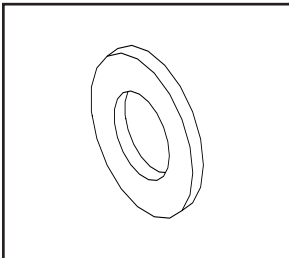

Position 22

M12 Washer

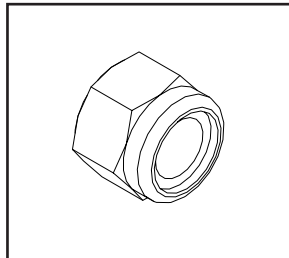

Position 23

M12 Nut

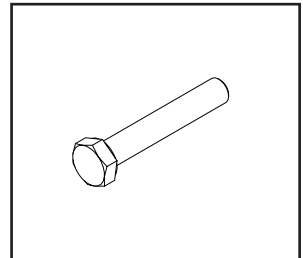

Position 24

M10x40

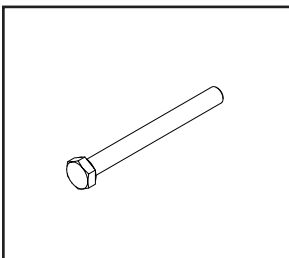

Position 25

M10x60

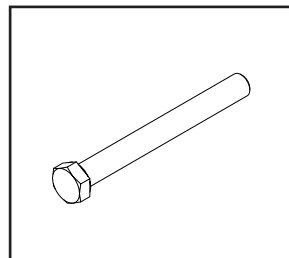

Position 26

M10x100

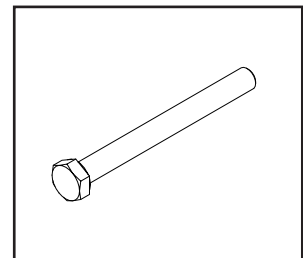

Position 27

M10x70

Assembly elements:

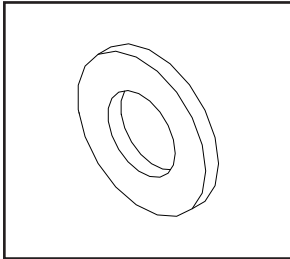

Position 28

M10 Washer

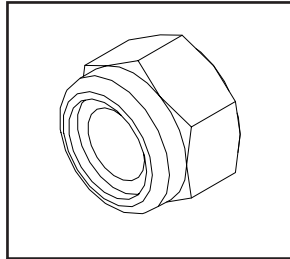

Position 29

M10 Nut

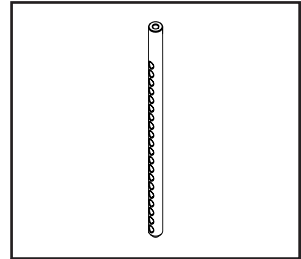

Position 30

**WS_Selector
Bar_50KG**

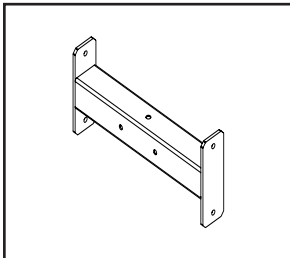

Position 31

**Pulley Tower_
connecting profile**

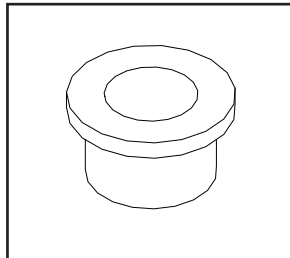

Position 32

Bushing fi 14-10

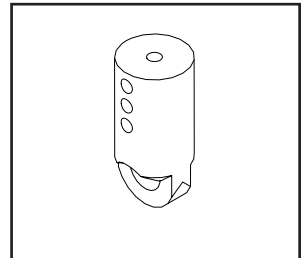

Position 33

Cable Termination

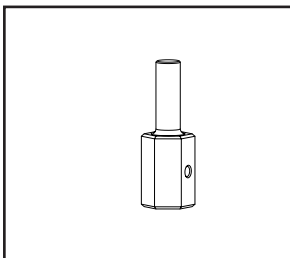

Position 34

**Cable Termination_
Thread**

Assembly instruction:

STEP: 1

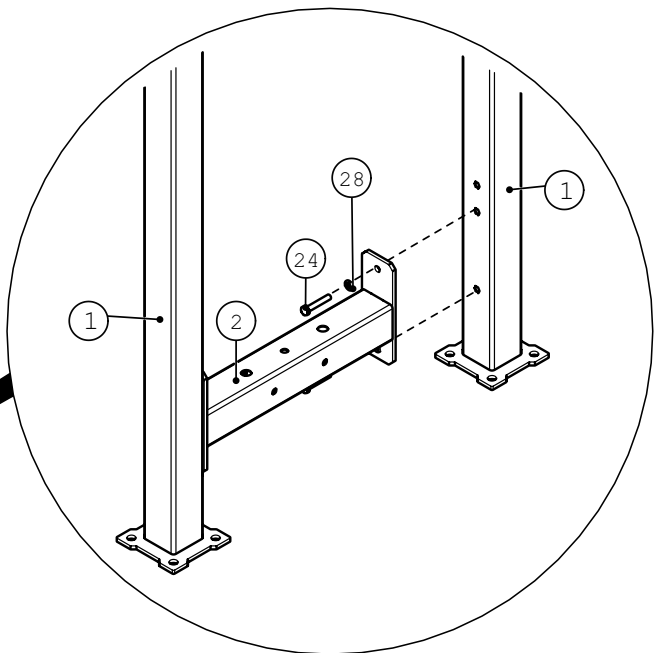
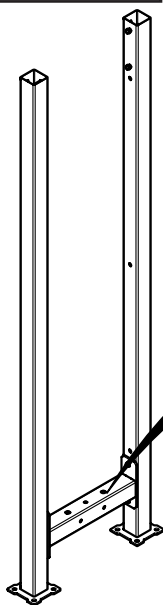

STEP: 2

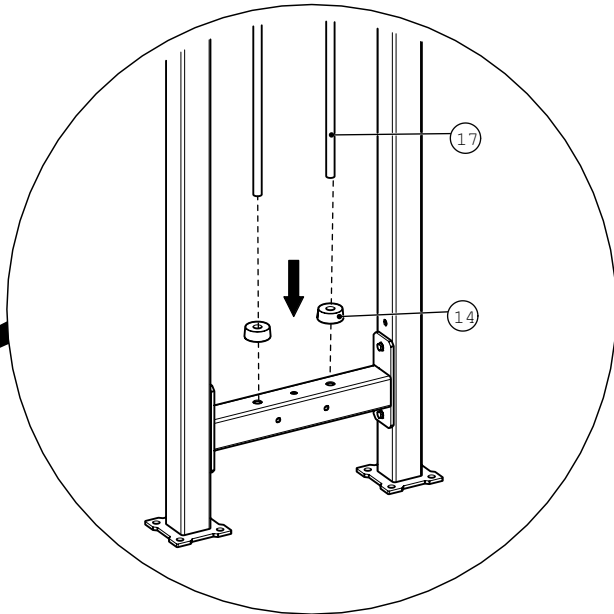
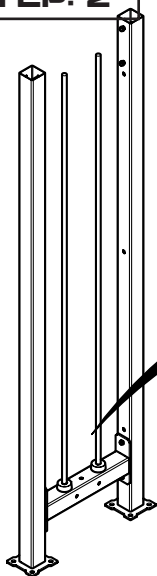

Assembly instruction:

STEP: 3

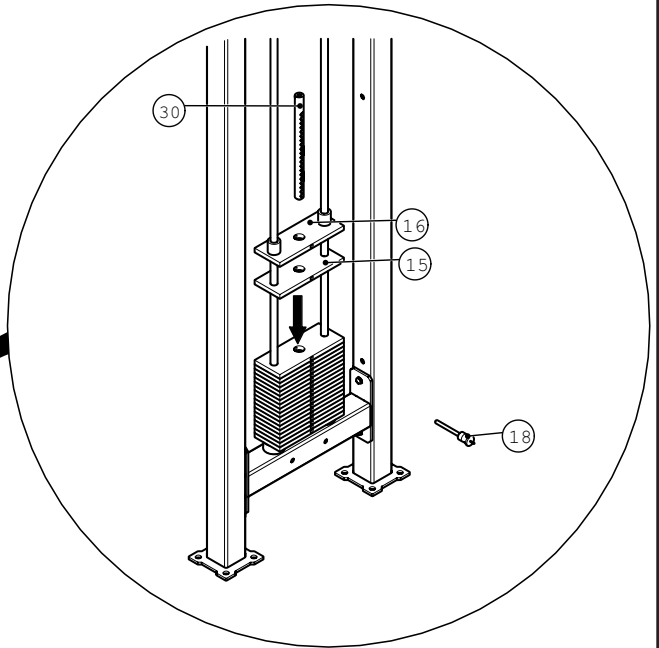
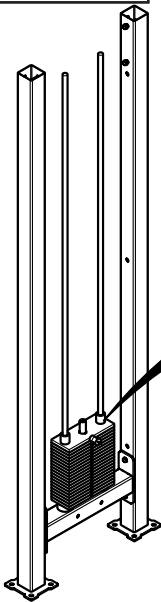

STEP: 4

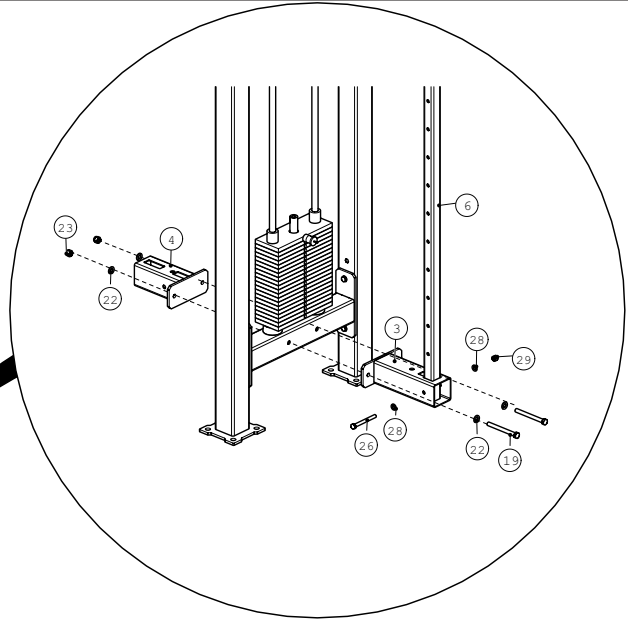
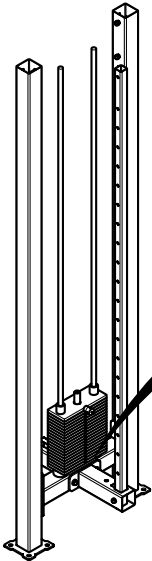

Assembly instruction:

STEP: 5

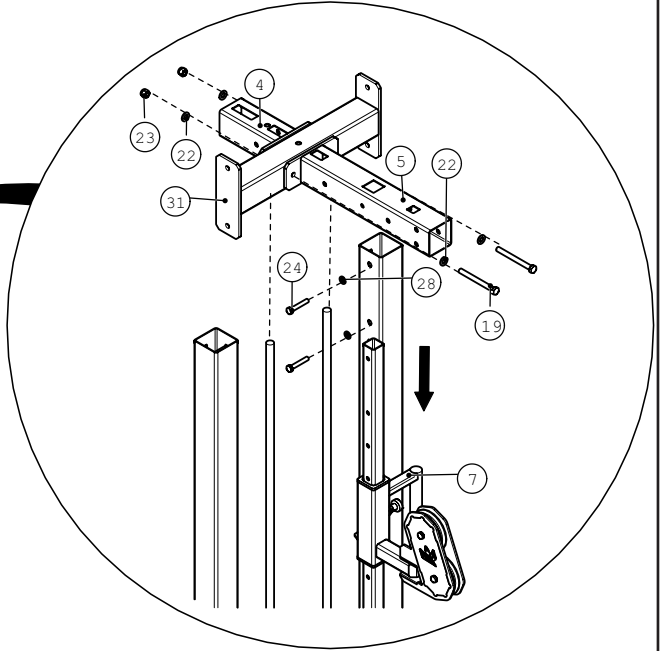
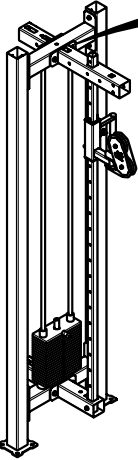

STEP: 6

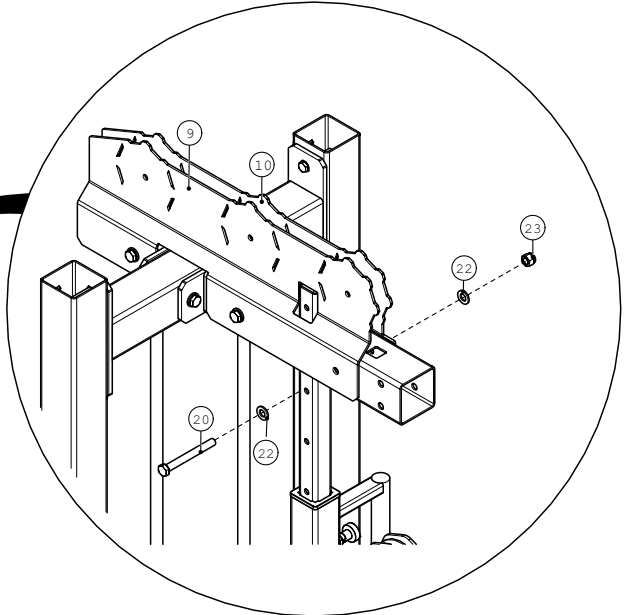
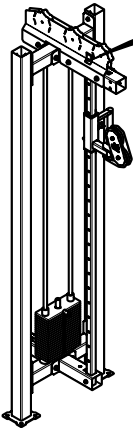

Assembly instruction:

STEP: 7

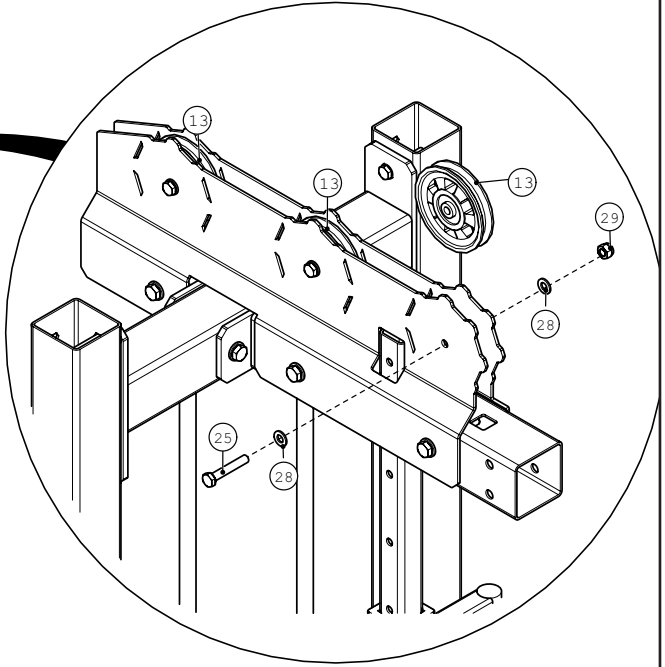
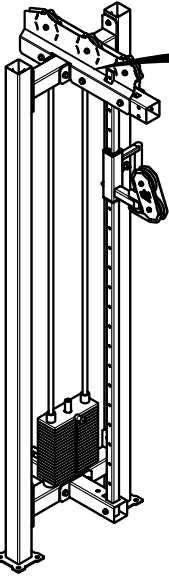

STEP: 8

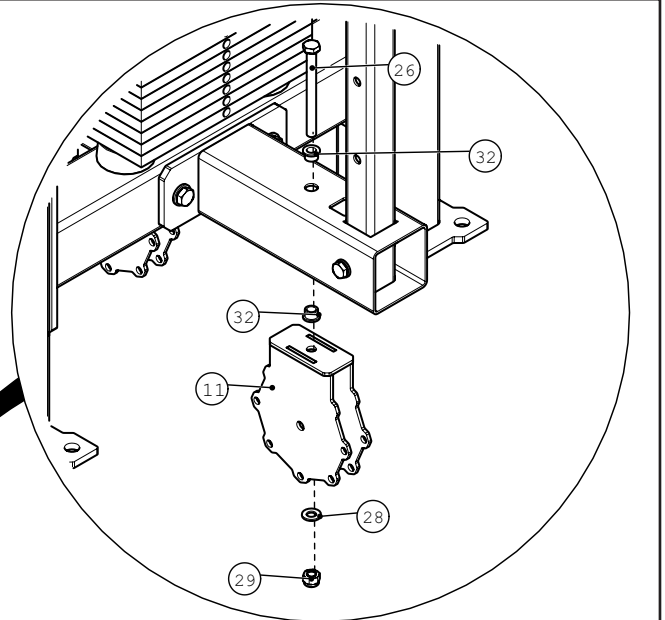
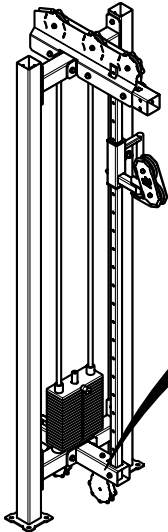

Assembly instruction:

STEP: 9

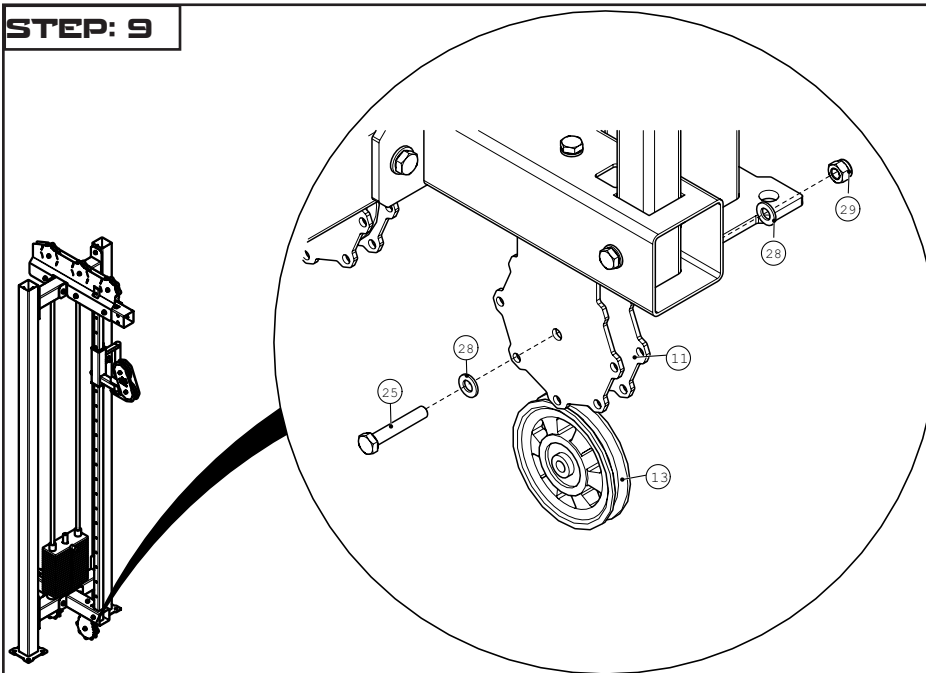

STEP: 10

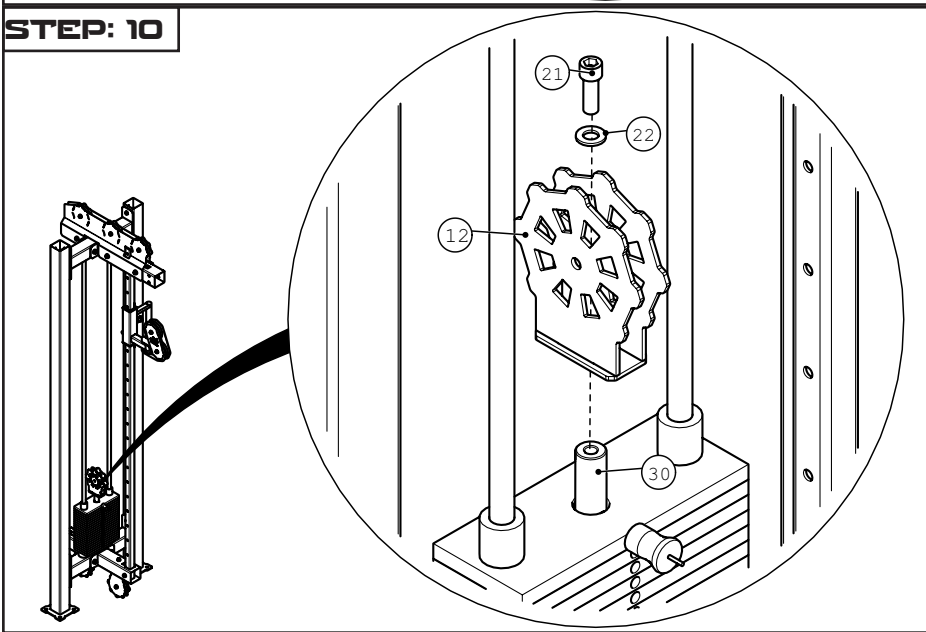

Assembly instruction:

STEP: 11

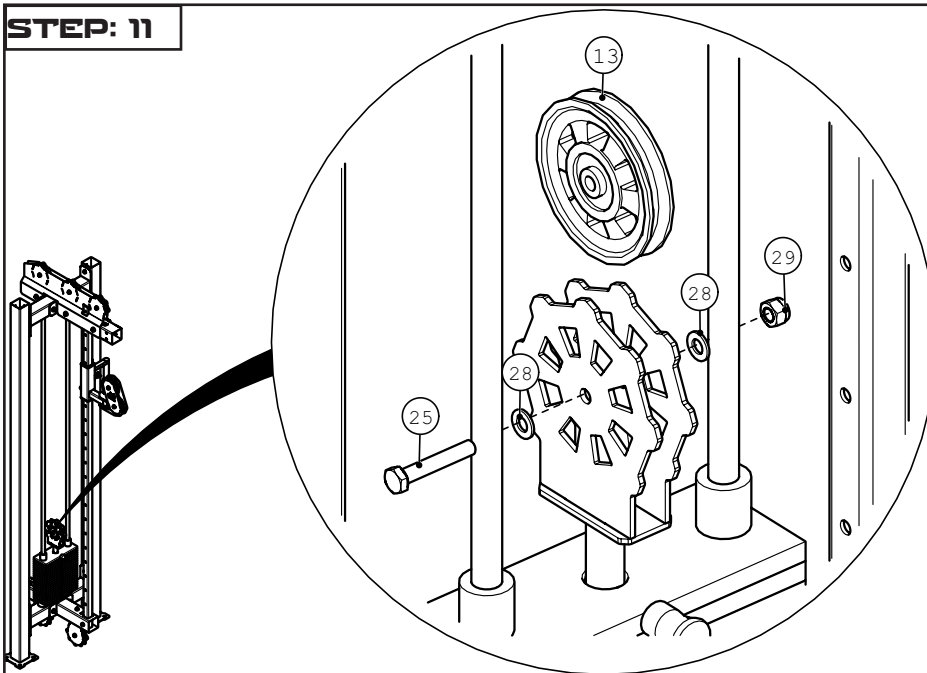

STEP: 12

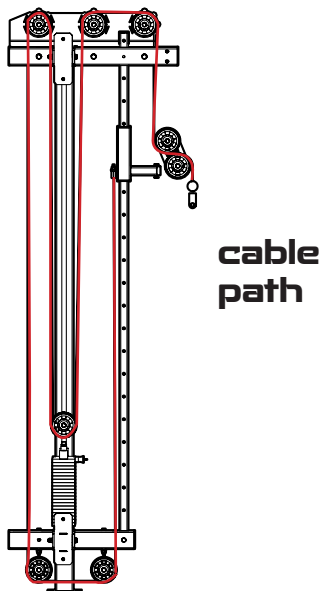

Assembly instruction:

STEP: 13

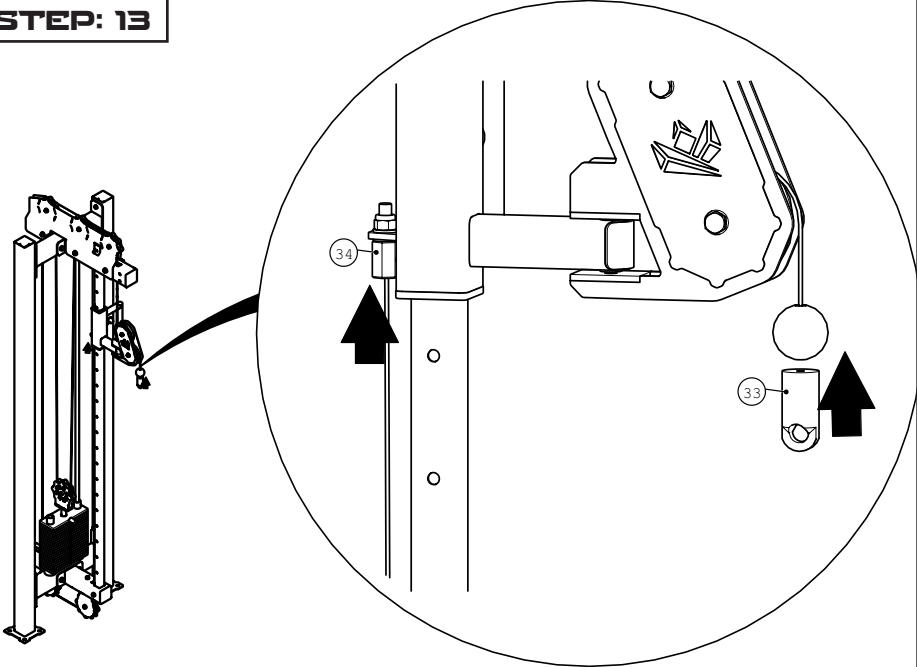

STEP: 14

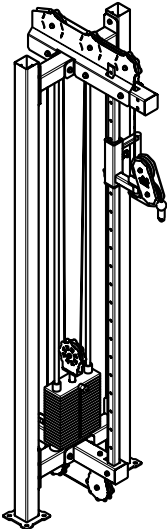

Adj. Cable CrossOver

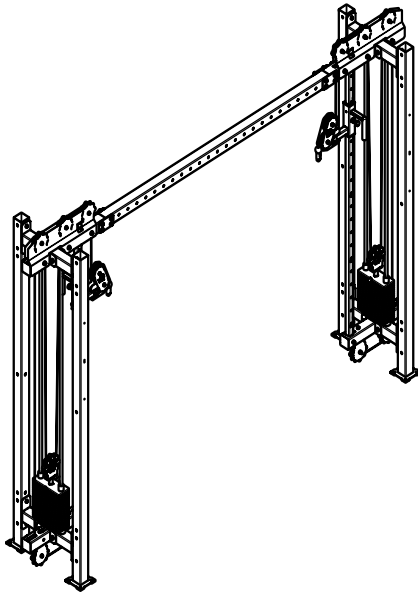

KingsBox®
BUILDING BETTER HUMANS

Assembly elements:

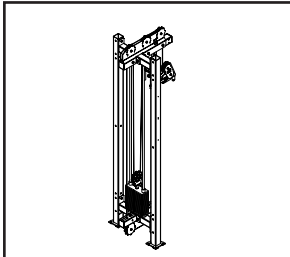

Position 1

PT_Bridge Tower

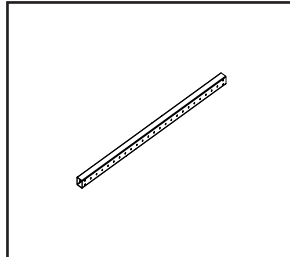

Position 2

**PT_Long Connecting
Profile**

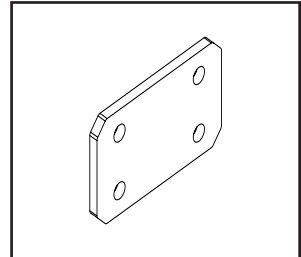

Position 3

PT_Link Plate

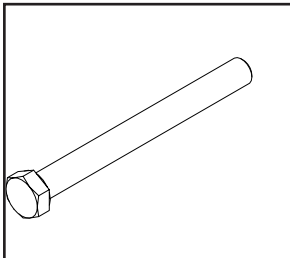

Position 4

M12x120

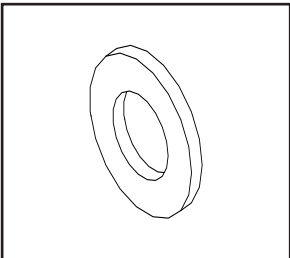

Position 5

M12 Washer

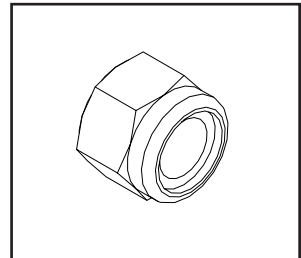

Position 6

M12 Nut

Assembly instruction:

STEP: 1

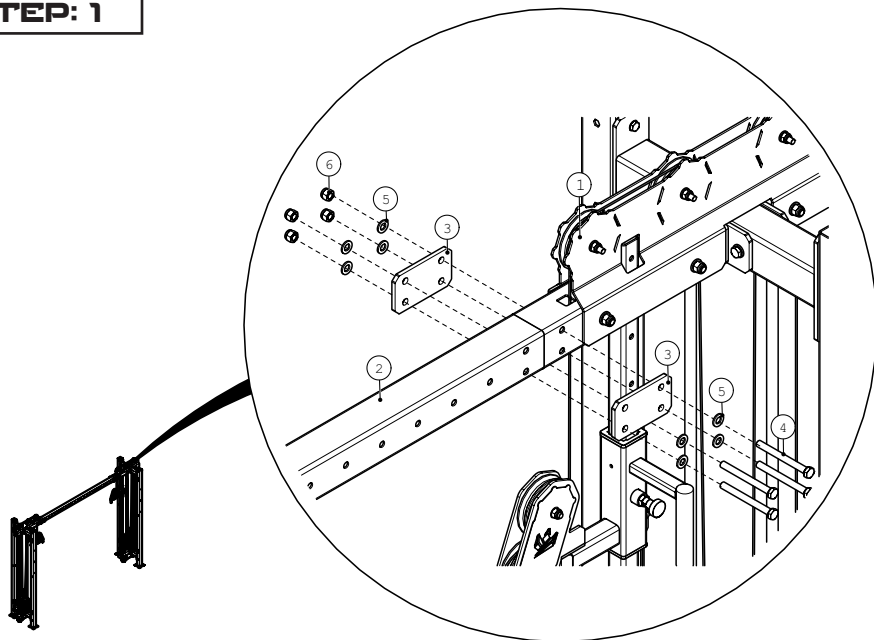

STEP: 2

