

# Supine board

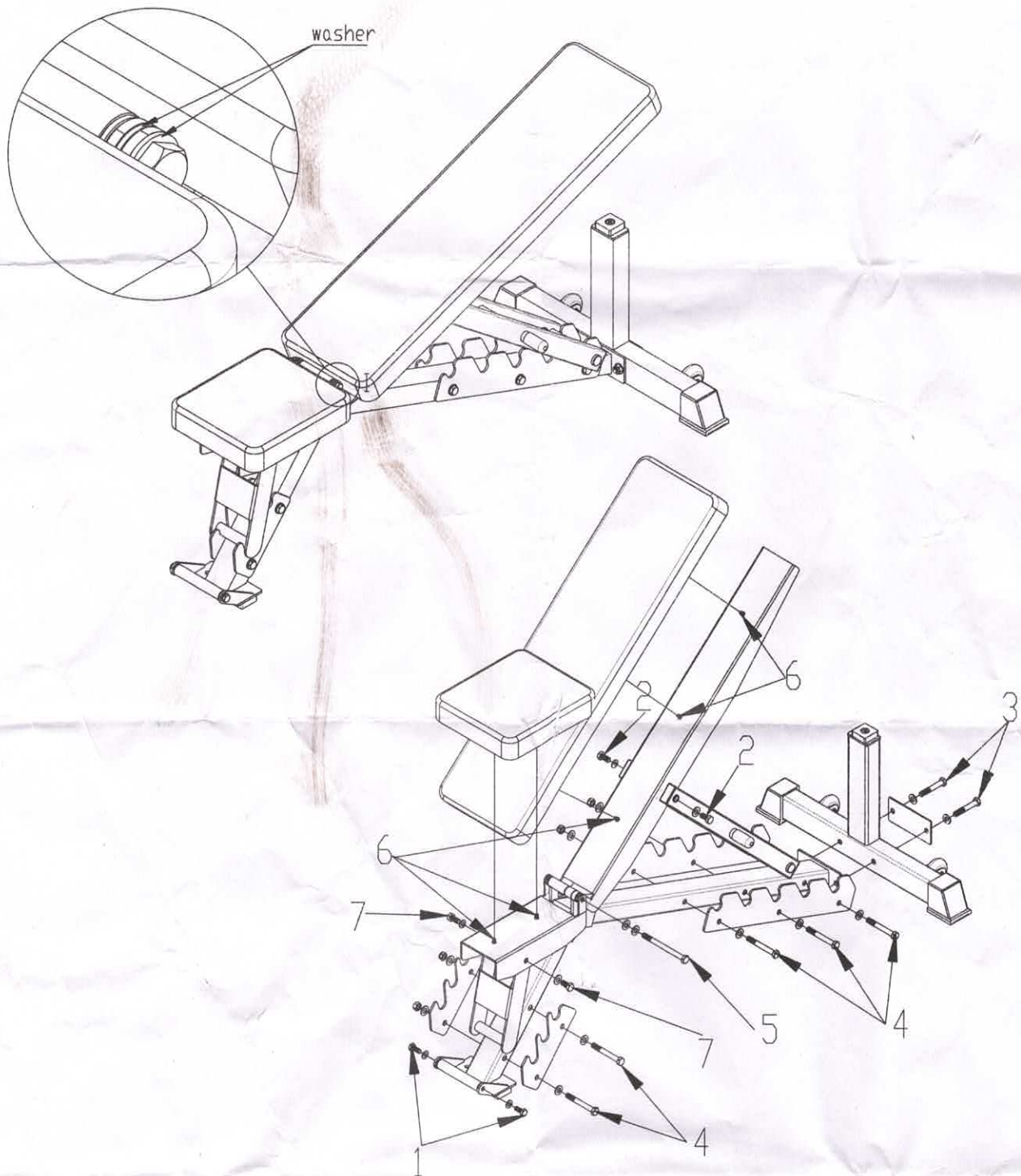

Sequence Number	Specifications	Number
1	BOLT M10*20 + WASHER	2
2	BOLT M12*45 + TWO WASHERS + NUT	2
3	BOLT M12*75 + TWO WASHERS + NUT	2
4	BOLT M12*95 + TWO WASHERS + NUT	5
5	BOLT M12*140 + FOUR WASHERS + NUT	1
6	BOLT M8*20 + WASHER	5
7	BOLT M12*25 + TWO WASHERS + NUT	2